

1A/2A, 1C/2C, AND 1E TYPES COIN TELEPHONE SETS

CONTENTS	PAGE	CONTENTS	PAGE
1. GENERAL	2	H. Instruction Cards (2-Type Set)	30
2. IDENTIFICATION	3	I. OUT-OF-SERVICE Sticker	32
A. Ordering Guide	3	J. Number Card [8U (MD), 8W (MD), or 8WA Dial]	32
B. Design Features	3	K. Number Card (TOUCH-TONE® Set)	33
C. Basic Operating Features	9	WIRING AND GROUNDING	33
3. INSTALLATION	16	4. OPERATION TESTS AND TROUBLE ANALYSIS	36
LOCATION	16	5. MAINTENANCE	65
BACKBOARDS AND SECURITY STUDS	18	A. Clearing Chute of Foreign Material or Stuck Coin	65
MOUNTING ARRANGEMENTS	19	B. Electrical Troubles	66
COMPONENTS	21	C. 1A Coin Relay	66
A. Coin Cover Unit (1-Type Set)	21	D. Coin Hopper	67
B. Door and Faceplate Assembly (2-Type Set)	21	E. Coin Trap and Associated Parts	69
C. Chute-Totalizer	22	F. Return Chute Assembly	70
Increasing Rate	24	G. Coin Return Assembly	70
Decreasing Rate	24	H. Ringer	72
D. Coin Chassis	27	I. Auxiliary Ringer	73
E. Coin Receptacle (Cash Box)	29	J. Handset	73
F. Instruction Cards (1-Type Set)	29	K. Coin Dial Unit	76
G. 11A Card Holder	29		

NOTICE

Not for use or disclosure outside the
Bell System except under written agreement

CONTENTS	PAGE
L. Fingerwheel [8U (MD), 8W (MD), or 8WA Dial]	76
M. Information Plate and Plate Assemblies	76
N. Magnetic Coin Stop and Information Plate (D-180848 Kit of Parts)	78
O. 812363612 (P-23F361) Entrance Stop	81
P. Modification of Cover Unit Chute Guide (Limit Stop)	81
Q. 840360184 Knob and Shaft Assembly	81
R. 840358725 Handle and Shaft Assembly	82
S. Radio Signal Suppression	82
T. Polarity Guard (D-180893 Kit of Parts)	83
6. CONVERSIONS	84
7. MANUAL EXTENSION STATION	84
8. CLEANING AND TOUCH-UP	85
9. CONNECTIONS	85

1. GENERAL

1.01 This section contains identification, installation, maintenance, and connection information on the 1A/2A-, 1C/2C-, and 1E-type coin telephone sets (Fig. 1 and 2).

1.02 This section is reissued to add:

- KS-20950, List 2 cover panking tool
- KS-22473 leveling device
- KS-22551 Gauge
- 70B Dial

- G13D handset
- RFI information
- 20A coin chute—shimmed dime slot
- New Table F.

Since this reissue covers a general revision, arrows ordinarily used to indicate changes have been omitted.

1.03 Coin telephone set codes are described in Table A.

1.04 A detailed description of these sets can be found in Public Services Crafts' Manual.

1.05 The 1A/1C rotary dial sets can be converted to 1A/1C TOUCH-TONE sets by replacing the coin cover unit. Verify correct wiring. No provisions are made for modifying the 2A/2C rotary dial sets to 2A/2C TOUCH-TONE sets.

1.06 Coin telephone sets in dial tone first can be used only with those central office switching systems that have been converted to dial tone first.

1.07 The 1E-type postpay coin telephone sets have no provision for coin refund; however, slugs or bent coins trapped in the chute can be cleared and will fall into the coin return when the coin release lever has been operated.

1.08 Overall dimensions of the 1A/1C/1E-type coin telephone sets are:

- Height—21 inches
- Width—7-3/4 inches
- Depth—6-1/4 inches

1.09 Overall dimensions of the 2A/2C-type coin telephone sets are shown in Fig. 3.

1.10 1A/2A-type sets are MD.

TABLE A
CODE SIGNIFICANCE

CODE	FIG.	HOUSING	MODE OF OPERATION	DIAL	
1A1	1	Box Type	Coin First Only	Rotary	
1A2				TOUCH-TONE	
2A1	2	Panel Type		Rotary	
2A2				TOUCH-TONE	
1C1	3	Box Type		Rotary	
1C2				TOUCH-TONE	
2C1	4	Panel Type		Coin First or Dial Tone First	Rotary
2C2				TOUCH-TONE	
1E1	5	Box Type	Post Pay	Rotary	
1E3				None (Manual)	

2. IDENTIFICATION

A. Ordering Guide

2.01 Basic Telephone Set:

- Set, Coin Telephone, 1C1, 1C2, 2C1, 2C2, 1E1, or 1E3

Note 1: See Tables B and C for color selection.

Note 2: All 1C/2C-type sets are shipped from the factory wired for coin-first service. Following is an example of how a typical set is equipped (see Table C):

1—Example—1C1-51 will be a green, box type set equipped with:

- 70A1-50 coin cover unit which includes a 60A1-44 coin dial unit which contains an 8WA dial with an 818418527 number plate
- G3AH-52 handset
- 20A1A chute-totalizer

- 31A coin chassis

- 1AA coin relay

- 2A-51 cash compartment door.

2.02 Components: See Tables B, C and Fig. 1, 2.

Note: Coin cover unit and coin dial units can be ordered from the factory-wired for coin-first or dial-tone-first service.

2.03 Associated Apparatus (Order Separately): See Table D.

2.04 Optional Equipment (Order Separately): See Table E.

B. Design Features

2.05 All parts are contained in a high-security steel housing. The coin cover unit/door and faceplate assembly has six locking points actuated by a 719A tool (Fig. 4) and secured by a 29A lock. A 32A special purpose lock may be used in 1-type sets.

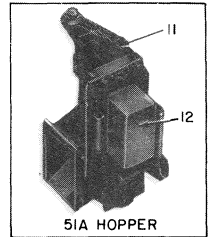
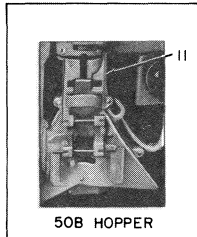
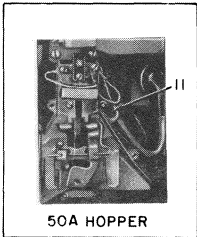
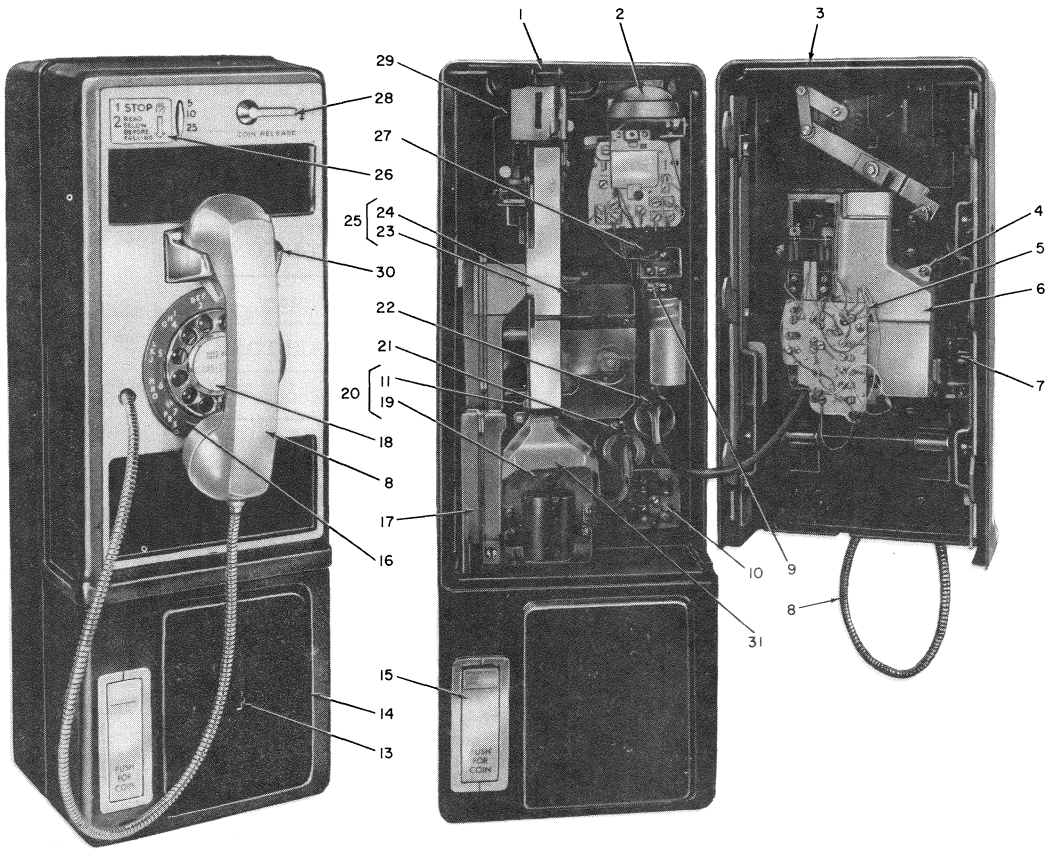

Fig. 1—1-Type Coin Telephone Set

LEGEND (FIG. 1)

- 1 — 812755429 (P-27E542) Chute Locking Lever and 812754976 (P-27E497) Spring
- 2 — C4-Type Ringer
- 3 — Coin Cover Unit*
- 4 — 840157390 Self-locking Screw
- 5 — TB2
- 6 — Coin Dial Unit*
- 7 — 811554443 (P-15E444) Coverplate and 801816786 (P-181678) BHM Screw
- 8 — Handset*
- 9 — Coin Chassis*
- 10 — TB3 (1C Set Only)
- 11 — Hopper Assembly*
- 12 — Delay Circuit Assembly
- 13 — Slot For 719A Tool
- 14 — 2-Type Door
- 15 — 812165462 (P-21F546) Coin Return Assembly
- 16 — Number Plate or Apparatus Blank*
- 17 — 811557304 (P-15E730) Return Chute Assembly
- 18 — Dial*
- 19 — Coin Relay (1A/1C-Type Sets Only)*
- 20 — Coin Relay and Hopper Assembly (1A/1C-Type Sets Only)*
- 21 — P2
- 22 — P1
- 23 — Chute*
- 24 — Totalizer*
- 25 — Chute-Totalizer*
- 26 — Information Plate*
- 27 — TB1
- 28 — 840358725 Shaft and Handle Assembly
- 29 — 812363612 (P-23F361) Entrance Stop
- 30 — 840358303 Hook
- 31 — 811057835 Cover

* Refer to Tables B and C.

Fig. 1—Legend

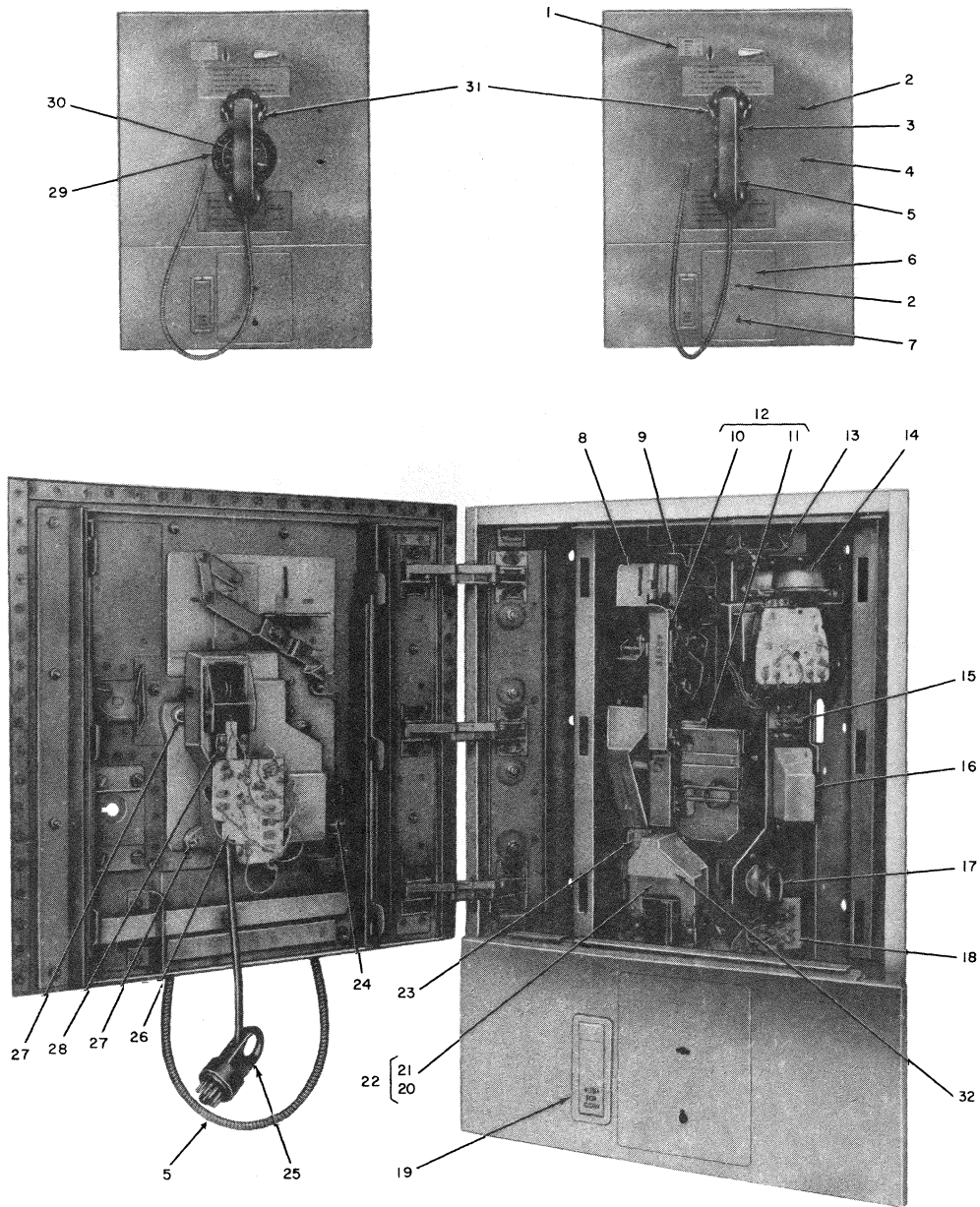

Fig. 2—2-Type Coin Telephone Set

LEGEND (FIG. 2)

- 1 – Information Plate*
- 2 – Slot for 719A Tool
- 3 – Number Card
- 4 – Slot for 29A Lock
- 5 – Handset*
- 6 – 5A Door
- 7 – Slot for 30-Type Lock
- 8 – 812363612 (P-23F361) Entrance Stop
- 9 – 812755429 (P-27E542) Chute Locking Lever and 812754976 (P-27E497) Spring
- 10 – Chute*
- 11 – Totalizer*
- 12 – Chute-Totalizer*
- 13 – 7A Clip
- 14 – C4-Type Ringer
- 15 – TB1
- 16 – Coin Chassis*
- 17 – P2
- 18 – TB3 (2C Set Only)
- 19 – Coin Return Assembly
- 20 – Coin Relay*
- 21 – Hopper Assembly*
- 22 – Coin Relay and Hopper Assembly*
- 23 – Return Chute Assembly*
- 24 – 811554443 (P-15E444) Coverplate and 801816786 (P-181678) BHM Screw
- 25 – P1
- 26 – TB2
- 27 – 840157390 Self-locking Screw
- 28 – Coin Dial Unit*
- 29 – Number Plate Assembly*
- 30 – Dial*
- 31 – 840358303 Hook
- 32 – 811057835 Cover

* Refer to Tables B and C.

Fig. 2—Legend

This Page Intentionally Left Blank

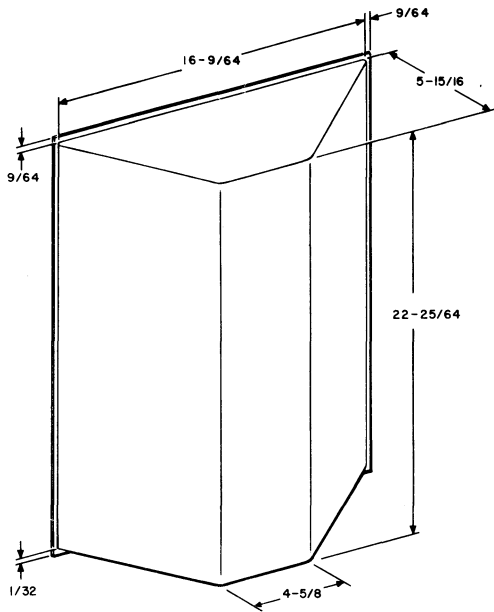

- NOTES:
 1. ALL DIMENSIONS SHOWN ARE IN INCHES.
 2. THE SWITCHHOOK AND HANDSET EXTEND 2-3/4 INCHES IN FRONT OF THE FACEPLATE.

Fig. 3—Rear View of Panel Set Showing Dimensions

- 2.06** The 1-type set cash compartment door has four locking points actuated by a 719A tool. The 2-type set cash compartment door has five locking points; three are actuated by a 719A tool; two are stationary. All cash compartment doors are secured by a 30-type lock.
- 2.07** Provision is made for use of four security studs.
- 2.08** The set is designed to accept U.S. nickels, dimes, and quarters only.
- 2.09** All sorting of coins is done internally by the coin chute.
- 2.10** Sets have transmission characteristics of 500-type telephone sets.
- 2.11** Electrical connections of field replaceable coin cover unit and chute-totalizer are made by plug and jack arrangement.

2.12 Each set is equipped with a totalizer mounted on the side of the coin chute. The totalizer cam shaft is rotated 10 degrees by each nickel deposited, 20 degrees by each dime, and 50 degrees by each quarter. Each cog (10 degrees) on the gear wheel represents a 5-cent increment. The totalizer can be set for an initial rate of any amount from 5 cents to 45 cents in 5-cent increments. A call cannot be made, except as described in paragraph 2.17 until the correct initial rate has been deposited. All totalizers are preset at the factory for a 10-cent initial rate.

2.13 Operator identification of coin deposits is by oscillator generated beep tones. A nickel is identified as one beep, a dime as two beeps, and a quarter as five rapid beeps. These tones may be audible in the handset. In switching systems designed for machine detection of customer coin deposits, sets equipped with dual frequency (DF) type chassis must be used.

2.14 Several versions of totalizers may be found in the field as shown in Fig. 5. The CF-DTF mode switch on current models or PP-DTF connector on older models can be moved manually from one position to another.

2.15 The black reference mark appearing on the ratchet wheel indicates whether the totalizer shaft is off-normal or in its "home" position. As viewed from the front of the coin telephone set, a totalizer is in its home position when the mark is at a point 1 tooth to the left of the 6 o'clock position.

C. Basic Operating Features

2.16 Coin First Service (Prepay System):

For coin first operation, the coin station line circuit at the central office responds to ground start control. A start circuit must be completed between ring lead and the ground lead at the coin telephone set before the dialing and talking circuit is connected and energized.

2.17 Dial Tone First Service (Prepay System):

System operation for dial tone first is on a loop start basis with ground present test for initial rate, and polarity reversal for subsequent deposits. This system provides dial tone before coin deposit and allows call completion to certain numbers without a coin deposit. Loop start circuit control is completed between the ring

TABLE B
COMPONENT AND COLOR SECTION
(1A/2A-TYPE SETS)

COIN TEL SET	FRONT COVER		DIAL AND HOUSING		DIAL	NUMBER PLATE ASSY	INFORMATION PLATE	HANDSET
	COVER UNIT ASSY (MD)	COIN COVER UNIT *	DIAL AND HOUSING ASSY (MD)	COIN DIAL UNIT *				
1A1-03 (Black)	819054032 (P-90E403)	70A1-03	841317241 or 819042748 (P-90D274)	60A1-44	8WA or 8W (MD)	818418527		
1A1-44 (Chrome)	819054446 (P-90E444)	70A1-44		60A2-44				
1A1-51 (Moss Green)	819054511 (P-90E451)	70A1-51		60A2-44				
1A2-03 (Black)	819055039 (P-90E503)	71A1-03	840346977	61A1-44	70A (MD) or 70B	840156319		G3AH-52† G3AK-52† G3AHF-52† G3AKF-52† G13-Type‡
			819042755 (P-90D275)		35T3A			
1A2-44 (Chrome)	819055443 (P-90E544)	71A1-44	840346977	61A1-44	70A (MD) or 70B			
			819042755 (P-90D275)		35T3A			
1A2-51 (Moss Green)	819055518 (P-90E551)	71A1-51	840346977	61A1-44	70A (MD) or 70B			
			819042755 (P-90D275)		35T3A			
2A1-67 (Brushed Stainless)				61A1-44	8WA or 8W (MD)	818720526		
2A2-67 (Brushed Stainless)				61A1-44	70A (MD) or 70B			
					35T3A			

* These coin cover unit and coin dial unit codes are for ordering information to obtain the unit, wired, tested, and equipped for the correct mode of operation. Since the units may be field converted from one type to another, maintenance, and installation should be based on the first three (3) characters of the code only. It is important therefore to ensure that the unit being used is wired properly and that the coin cover unit has the proper information plate and instruction cards for the type of service with which it is being used. All rotary coin cover units are equipped with 8WA dials and all TOUCH-TONE coin covers units are equipped with 70A (MD) or 70B dials.

† G3AHF-52 and G3AKF-52 are optional flame retardant handsets and cords that can replace the G3AH-52 and G3AK-52 respectively. The G3AK and G3AKF are equipped with a moisture resistant transmitter barrier and special transmitter cap.

‡ A G13D amplified handset can be used. Refer to Section 501-211-102 for complete information.

TABLE B (Contd)
COMPONENT AND COLOR SECTION
(1A/2A-TYPE SETS)

HOUSING AND MTG PLATE ASSY	CHUTE-TOTALIZER	COIN CHASSIS	COIN RELAY AND HOPPER ASSY	RETURN CHUTE ASSY	COIN RETURN ASSY	COIN RECP RAIL	CASH COMPT. DOOR
818512036 (P-85A203)	811554286 (P-15E428) Consist of 20A Chute 811555796 (P-15E579) Totalizer	840693634 with DF Oscillator	1AA Coin Relay Consist of 1A Coin Relay and 811557172 Coin Hopper Assembly	811557305 (Current return chute assemblies are made of plastic instead of diecasting)	812165462	1B	2A-03 or 2B-03 (Optional)
818512444 (P-85A244)							2A-44 or 2B-44 (Optional)
818512519 (P-85A251)							2A-51 or 2B-51 (Optional)
818512036 (P-85A203)							2A-03 or 2B-03 (Optional)
818512444 (P-85A244)						2A-44 or 2B-44 (Optional)	
818512519 (P-85A251)	2A-51 or 2B-51 (Optional)						
						1D	5A-67

TABLE C
COMPONENT AND COLOR SECTION
(1C/2C/1E-TYPE SETS)

COIN TEL SET	MODE OF OPERATION	FRONT COVER		DIAL AND HOUSING		DIAL	NUMBER PLATE ASSY	INFORMATION PLATE	HANDSET				
		COVER UNIT ASSY (MD)	COIN COVER UNIT *	DIAL AND HOUSING ASSY (MD)	COIN DIAL UNIT								
1C1-03 (Black)	CF	819054032	70A1-03	841317241 or 819042748 (P-90D274)	60A1-44	8WA or 8W (MD)	818418527	840156319 For Coin First	G3AH-52† G3AK-52† G3AHF-52† G3AKF-52 † G13-Type‡				
	DTF	(P-90E403)	70A2-03		60A2-44								
1C1-44 (Chrome)	CF	819054446	70A1-44		60A1-44								
	DTF	(P-90E444)	70A2-44	60A2-44									
1C1-51 (Moss Green)	CF	819054511	70A1-51		60A1-44								
	DTF	(P-90E451)	70A2-51		60A2-44								
1C2-03 (Black)	CF	819055039	71A1-03	840346977 (70A Dial) or 819042755 (P-90D275)	61A1-44	70A (MD), or 70B, 35T3A (MD)	818720526	840156327 For Dial Tone First	(Used on 1C-and 2C-Type sets only)				
	DTF	(P-90E503)	71A2-03		61A2-44								
1C2-44 (Chrome)	CF	819055443	71A1-44		61A1-44								
	DTF	(P-90E544)	71A2-44	61A2-44									
1C2-51 (Moss Green)	CF	819055518	71A1-51	(35T3A Dial)	61A1-44								
	DTF	(P-90E551)	71A2-51		61A2-44								
2C1-67 (Brushed Stainless)	CF			841317241 or 819042748 (P-90D274)	60A1-44	8WA or 8W (MD)	818720039						
	DTF				60A2-44								
2C1-84 (Bronze)	CF			841317258 or 840152227	60A1-84							G3AH-03, G3AK-03, G13-Type‡	
	DTF				60A2-84								
2C2-67 (Brushed Stainless)	CF			840346977	61A1-44	70A (MD), 70B, 35T3A (MD)	61A2-44			818720039			G3AH-52† G3AK-52† G3AHF-52† G3AKF-52 † G13-Type‡
	DTF				61A2-44								
	CF			819042755	61A1-44								
	DTF				61A2-44								
2C2-84 (Bronze)	CF			840347173	61A1-84	70A (MD), 70B, 35T3A (MD)	61A2-84			818720039			G3AH-03, G3AK-03, G13-Type‡
	DTF				61A2-84								
	CF	840157580	61A1-84										
	DTF		61A2-84										
1E1-03 (Black)	Dial Post Pay	840658033	70A5-03	841317241 or 819042748 (P-90D274)	60A2-44	8WA or 8W (MD)	818418527	840156087	G3AH-52† G3AK-52† G3AHF-52† G3AKF-52 † G13-Type‡				
1E1-44 (Chrome)		840658447	70A5-44										
1E1-51 (Moss Green)		840658512	70A5-51										
1E3-03 (Black)	Manual Post Pay	840659031	70A4-03	841317266 or 812366516 (P-23F651) Housing Assembly	60A4-44	840994727 Apparatus Blank Assembly							
1E3-44 (Chrome)		840659445	70A4-44										
1E3-51 (Moss Green)		840659510	70A4-51										

* These coin cover unit and coin dial unit codes are for ordering information to obtain the unit, wired, tested, and equipped for the correct mode of operation. Since the units may be field converted from one type to another, maintenance, and installation should be based on the first three (3) characters of the code only. It is important therefore to ensure that the unit being used is wired properly and that the coin cover unit has the proper information plate and instruction cards for the type of service with which it is being used. All rotary coin cover units are equipped with 8WA dials and all TOUCH-TONE coin cover units are equipped with 70A (MD) or 70B dials.

† G3AHF-52 and G3AKF-52 are optional flame retardant handsets and cords that can replace the G3AH-52 and G3AK-52 respectively. The G3AK and G3AKF are equipped with a moisture resistant transmitter barrier and special transmitter cap.

TABLE C (Contd)
COMPONENT AND COLOR SECTION
(1C/2C/1E-TYPE SETS)

HOUSING AND MTG PLATE ASSY	CHUTE-TOTALIZER	COIN CHASSIS	COIN RELAY AND HOPPER ASSY	RETURN CHUTE ASSY	COIN RETURN ASSY	COIN RECP RAIL	CASH COMPT. DOOR
818512036 (P-85A203)	20A1A Consist of 20A Chute and 1A Totalizer	31A with DF Oscillator (31A2 Coin Chassis is available wired and tested for DTF service)	1AA Coin Relay Consist of 1A Coin Relay and 811557172 Coin Hopper Assembly	811557305 (Current return chute assemblies are made of plastic instead of diecasting)	812165462	1B	2A-03 or 2B-03 (Optional)
818512444 (P-85A244)							2A-44 or 2B-44 (Optional)
818512519 (P-85A251)							2A-51 or 2B-51 (Optional)
818512036 (P-85A203)							2A-03 or 2B-03 (Optional)
818512444 (P-85A244)							2A-44 or 2B-44 (Optional)
818512519 (P-85A251)							2A-51 or 2B-51 (Optional)
840656037	20A10A Consist of 20A Chute and 10A Totalizer	30B with DF Oscillator	51A or 50A (MD) Hopper Assembly	811557305 (Current return chute assemblies are made of plastic instead of diecasting)	812165462	1B	2A-03 or 2B-03 (Optional)
840656441							2A-44 or 2B-44 (Optional)
840656516			50B Hopper Assembly				2A-51 or 2B-51 (Optional)
840657035							2A-03 or 2B-03 (Optional)
840657449							2A-44 or 2B-44 (Optional)
840657514							2A-51 or 2B-51 (Optional)
							5A-67
					840152219	1D	5A-84
					812165462		5A-67
					840152219		5A-84

‡ A G13D amplified handset can be used. Refer to Section 501-211-102 for complete information.

This Page Intentionally Left Blank

TABLE D
ASSOCIATED APPARATUS
(Order Separately)

COIN TEL SET	CASH COMPT DOOR	COIN RECEP-TACLE	COIN RECEP-TACLE COVER	CASH COMP LOCK	COVER UNIT ASSY OR DOOR AND FACEPLATE ASSY LOCK	ALARM SWITCH
1A/1C/1E-Type	2A-3* (Black) 2A-44* (Chrome) 2A-51* (Moss Green)	1C-Type ‡	1E	30-Type	29A	1A Switch Kit & 257A Switch
2A-Type	5A-67† (Stainless)					257A Switch
2C-Type	5A-67† (Stainless) or 5A-84† (Bronze)					

* 2B door is optional.

† The cash compartment door is furnished with all panel phones.

‡ Sets equipped with false floor in coin vault will require a 1B receptacle.

TABLE E
OPTIONAL EQUIPMENT

ITEM	USED ON	REMARKS
1A Switch Kit	1-type Set	Refer to BSP 506-101-100
257A Alarm Switch	30-type Lock	BSP 506-101-100
Magnetic Coin Stop (D-180848 Kit of Parts)	1-type Set	Paragraphs 5.37 through 5.43
11A Card Holder	1-Type Set Mounted on a 178A backboard	Paragraph 3.28 through 3.30
D-180893 Kit of Parts (Polarity Guard)	1C2/2C2 Tel Set DTF Mode Only	Table R and Fig. 63

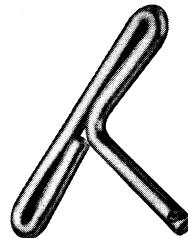

Fig. 4—719A Tool

lead and the tip lead at the coin telephone set when the handset is lifted and the switchhook is operated.

2.18 Dial Postpay Service: The system provides negative battery to the ring side of the line with tip grounded. Dial tone is received

TABLE F

TOOLS

ITEM	USE	REMARKS
719A Tool	To open coin cover unit (1-type set) or door and faceplate assembly (2-type set)	Fig. 4
KS-20950, List 2 Cover Parking Tool	To hold coin cover unit open (1-type set) during maintenance	See Note and Fig. 33
P11C Test Cord	Connects coin cover unit to chassis with door and faceplate assembly opened (2-type set)	Fig. 34
KS-22473 Leveling Device	To determine a vertical surface	Fig. 7
KS-14995, List 3 Tool	For trap and vane release test	Fig. 35
146B Bias Margin Gauge	To test bias margin on coin relay	Fig. 36

Note: KS-20950, List 1 tools that show excessive movement (looseness) or loose rivets should be replaced with a new tool, (preferably the List 2 if available), to avoid dropping the front cover.

and the party is dialed before coin deposit. Upon called party answer and following coin deposit, the CO switches the circuit for conversation.

2.19 Manual Postpay Service: The system provides negative battery to the ring side of the line with tip grounded. The operator is alerted when handset is lifted. Coin deposits are requested by the operator after connection to called party has been made.

2.20 Automatic Coin Toll Service (ACTS):

(a) ACTS is a feature, developed to further mechanize the handling of coin sent-paid toll calls at a No. 1 Traffic Service Position System (TSPS). This is accomplished by —

- (1) Providing automatic voice announcement to the customer.
- (2) Providing machine recognition of coin deposit signals.
- (3) Providing capability of checking for acceptability of the timing, frequency, and amplitude of coin signals generated by the coin telephone set.

(b) In order for a coin telephone set to be compatible with ACTS, it must be equipped

with a dual frequency (DF) oscillator mounted on the following chassis:

- 1A/2A-type sets—840693634 coin chassis
- 1C/2C-type sets—31A coin chassis
- 1E1 set—30B coin chassis

(c) The ACTS is compatible with coin telephone sets in the Coin-First (CF), Dial-Tone-First (DTF), and Dial Postpay (PP) mode of operation.

3. INSTALLATION

LOCATION

3.01 The 1-type coin telephone set can be installed in facilities described in Table G.

3.02 The 2-type coin telephone set can be installed in facilities described in Table H.

3.03 The following should be adhered to.

- Ensure that Drop and Inside Wires are protected. IW wires should be protected at least 6 feet from set.
- Check visibility, accessibility, and possible accident hazards in selecting locations.

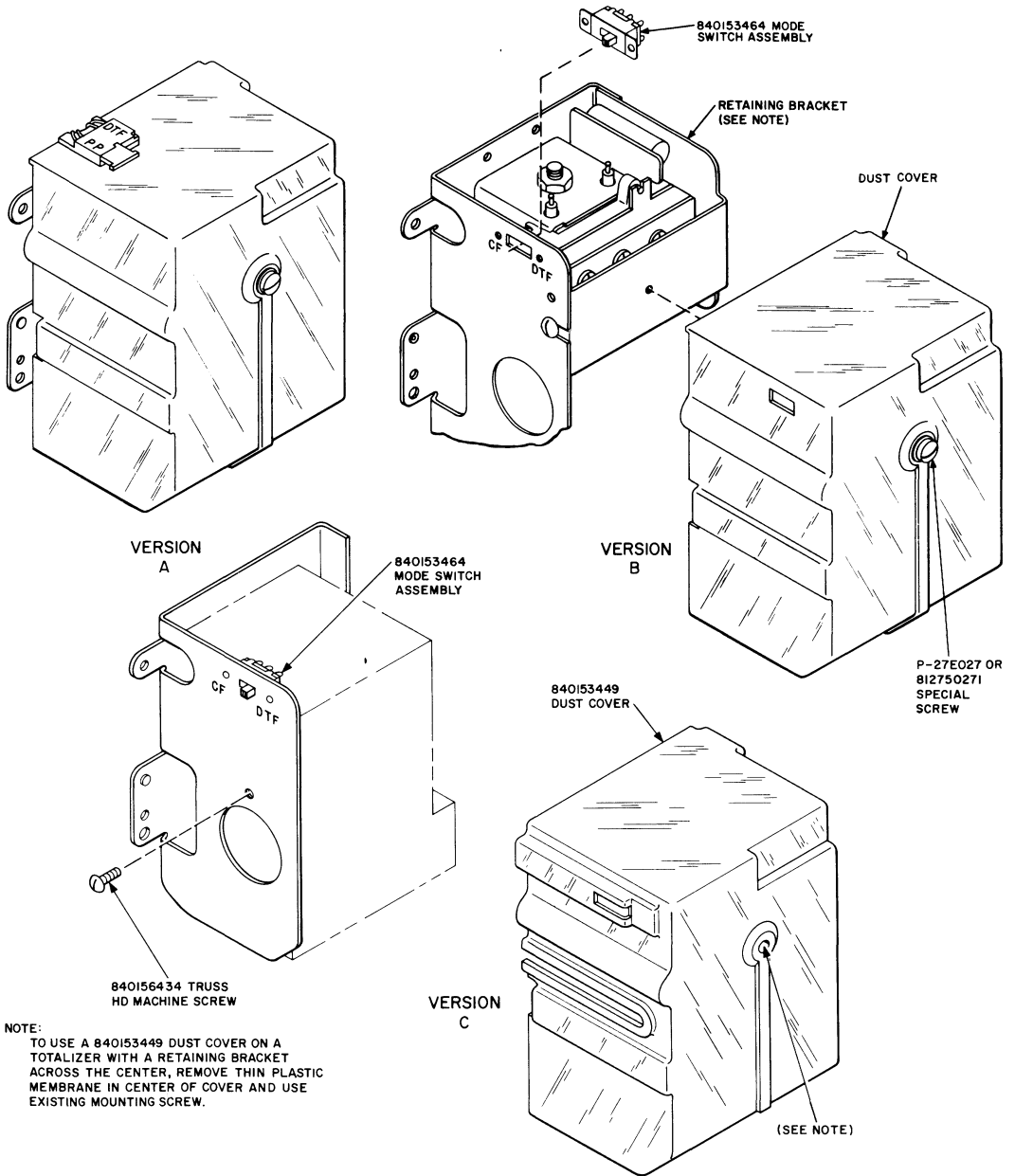

Fig. 5—Partial View of Totalizer

- Check mounting surfaces—Consult a supervisor before locating coin telephone set on finishes that would be expensive to repair if the set is removed.
- Check inductive effects—Locate set and associated wiring away from neon fixtures, transformers, or other interference-causing equipment.
- For outdoor installations, be sure that telephone set will not be subject to driving rain, salt spray, or splashed salt water from snow melt-off on sidewalks or roadside mountings.
- Ensure that security studs and thru-wall fasteners are used where possible. Always install all (7) 1/4-20 hardened screws when mounting a 1-type set. A single 1/4 I.D. flat washer may be used under each screw head for added security.

BACKBOARDS AND SECURITY STUDS

3.04 Refer to Section 506-100-101 and observe the following.



When mounting the coin telephone set, a vertical surface must be provided. A tilt greater than 1-1/2 degrees in any direction can cause chute malfunction. A vertical surface may be determined in A or B.

A. KS-22473 Leveling Device (Fig. 7)



The leveling device must be vertical and the pendulum must be able to move freely.

- (1) If a 178A backboard is used, position the leveling device so that the (2) studs insert into (2) of the center holes on the backboard and check that the black centerline on the pendulum is within the two 1.5 degree marks on the frame of the leveling device.
- (2) Align either long edge of the leveling device along the surface of the telephone enclosure (Fig. 8) on which the telephone set mounts and check that the black centerline on the pendulum

TABLE G
MOUNTING OF 1-TYPE SET (NOTE 3)

BACKBOARD, BOOTH, SHELF, MOUNTING, OR KIOSK	BACKBOARD REQUIRED	SECURITY STUDS (4 REQUIRED)	
		834080608 (P-40Y060) (SHORT SHOULDER-SHORT THREAD)	834080616 (P-40Y061) (LONG SHOULDER-SHORT THREAD)
178A-3 or -51 Backboard (Note 1)	Use on a vertical surface	•	
10- and 11-Type Booths	D-179939 or D-179940 Kit of Parts	•	
KS-14611 Booth	Furnished	•	
KS-16797 Booth	B-190387		•
KS-19206 Booth	KS-19206 List 6 Installation Kit	•	
KS-19267 Shelf	Furnished	•	
KS-19340 Booth	KS-19340 List 53	•	
KS-19425 Booth	Furnished		•
KS-19426 Mounting	KS-19426 List 7 Installation Kit		•
KS-19580 Booth	Furnished	•	
KS-19945 Shelf	Existing or 178A		•
KS-20194, L5 Shelf	178A-3 (Note 2)	•	
KS-20255 Kiosk	Furnished		•
KS-20842 Mounting	Furnished	•	
KS-21716 Booth	Furnished	•	
KS-21428 Phonecart	Furnished	•	
KS-21676, L2 Backboard		•	
KS-21571, L1, L2, L5, L6 Shelf	Furnished		•

TABLE G (Contd)
MOUNTING OF 1-TYPE SET (NOTE 3)

BACKBOARD, BOOTH, SHELF, MOUNTING, OR KIOSK	BACKBOARD REQUIRED	SECURITY STUDS (4 REQUIRED)	
		834080608 (P-40Y060) (SHORT SHOULDER- SHORT THREAD)	834080616 (P-40Y061) (LONG SHOULDER- SHORT THREAD)
KS-21977 Mounting	Furnished	•	

Note 1: Top edge of 178A backboard should be approximately 55-1/4 inches from floor for a universal coin slot height of 54 inches.

Note 2: A 178A backboard is furnished with each KS-20194 shelf unless otherwise specified.

Note 3: Seven 1/4-20 by 5/8-inch hardened RHM screws 812367902 (P-23F790) are furnished with each coin telephone set for mounting to backboard.

is within the two 1.5 degree marks on the frame of the leveling device.

(3) Align either long edge of the leveling device on a side surface of the enclosure which is known to be a true, vertical surface and again check that the black centerline on the pendulum is within the two 1.5 degree marks on the frame of the leveling device.

(4) When installing enclosure posts, it may be more convenient to use the front and side surfaces of the post, which is valid if these surfaces are true vertical surfaces.

(5) To check installed 1-type coin stations, align either long edge of the leveling device along the front chrome faceplate (Fig. 9) and again along the side of the station (Fig. 10) being sure to avoid the embosses and surface irregularities in these areas. Verify that the pendulum centerline is in both instances within the 1.5 degree limits marked on the frame.

(6) To check installed 2-type (panel) coin stations, open the front door and align the long edge of the leveling device on the front face of the

housing frame that is flush with the wall surface on the right side and read the level measurement as before. Then align the tool on the left side of this same frame and again read the level measurement.

Note: If the KS-22473 leveling device is not available use B.

B. Spirit Level

(1) Place a spirit level vertically against the mounting surface on which the set is to be installed.

(2) When a vertical reading is obtained, the end of the level opposite the point of contact shall be no farther from the mounting surface than shown in Table I.

(3) The left to right mounting axis shall also be within 1-1/2 degrees of true vertical.

3.05 Refer to Fig. 11, 12 and Tables G, H for security stud requirements.

MOUNTING ARRANGEMENTS

3.06 To gain access to the coin telephone set mounting holes.

(1) Remove coin cover unit (1-type) per 3.10 or open door and faceplate assembly (2-type) per paragraph 3.11.

(2) Remove chute-totalizer per paragraph 3.12.

(3) Remove coin chassis per paragraph 3.22.

1-Type

3.07 Refer to Table G for mounting applications.

2-Type

3.08 To fully recess a 2-type set in a wall.

(1) Ensure that wall thickness will accept the depth of set.

(2) Refer to Fig. 3 for dimensions of the set.

TABLE H

MOUNTING OF 2-TYPE SET (NOTE 2)

BOOTH, SHELF, OR MOUNTING	BACKBOARD REQUIRED	SECURITY STUDS (4 REQUIRED)		COVER REQUIRED (NOTE 1)
		834080608 (P-40Y060) (SHORT SHOULDER SHORT THREAD)	834080616 (P-40Y061) (LONG SHOULDER SHORT THREAD)	
KS-19206 Booth	KS-19206, List 7 Installation Kit	•		127B Fig. 6
KS-19340 Booth	KS-19340 List 54 Backboard	•		127B Fig. 6
KS-19426 Mounting	Furnished		•	KS-19426, List 34 Top Assembly
KS-19442 Booth	KS-19340 List 54 Backboard	•		127A Fig. 6
KS-20194 Shelf	Furnished	•		None
KS-20630 Booth	Furnished	None Required (Note 3)		
KS-21571 L3, L4, L7, L8 Shelf	Furnished		•	None

Note 1: Three No. 8-32 by 3/16 RHM screws are furnished with cover for installation.

Note 2: Thirteen 1/4-20 by 5/8-inch hardened RHM screws 812367902 (P-23F790) are furnished with each coin telephone set for mounting to backboard.

Note 3: Use thirteen 1/4-20 by 3/8 RHM screws in a KS-20630 booth in place of the 1/4-20 by 5/8 lg. furnished screws.

(3) Cut a hole in the wall:

- Height—22-25/64 inches
- Width—16-9/64 inches
- Depth—6 inches
- Bottom edge of cutout should be approximately 34 inches from floor for a universal coin slot height of 54 inches.



Ensure that the lip of the faceplate overlaps the wall around the hole.

3.09 Refer to Table H for all other mounting applications of the 2-type coin telephone set.

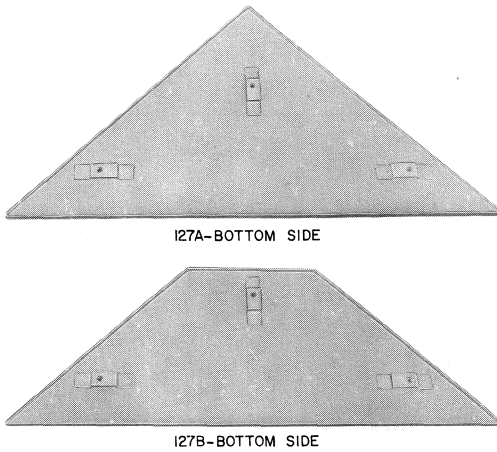

Fig. 6—127A and 127B Covers for Panel Sets

COMPONENTS

A. Coin Cover Unit (1-Type Set)

3.10 To remove coin cover unit.

- (1) Unlock coin cover unit lock.
- (2) Release locking mechanism with 719A tool by turning tool 1/8-turn counterclockwise.
- (3) Pull cover off about 3 inches to gain access to P1.
- (4) Disconnect P1 by carefully pulling straight out as cover is removed.

B. Door and Faceplate Assembly (2-Type Set)

THINKS *Exercise care to keep the set from tipping over when door is opened.*

3.11 To open door and faceplate assembly.

- (1) Unlock door and faceplate lock.
- (2) Release locking mechanism with 719A tool by turning 1/8-turn counterclockwise.
- (3) Open door approximately 3 inches to gain access to P1.

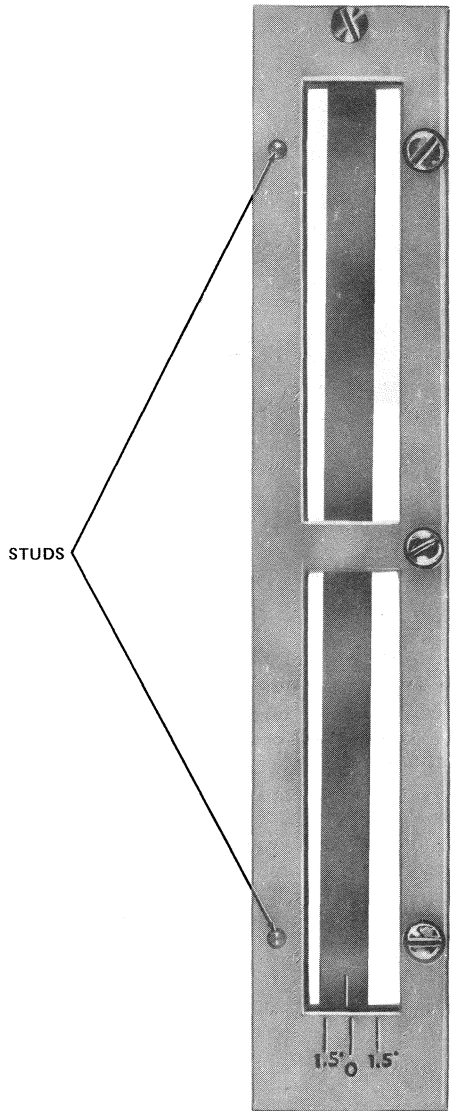

Fig. 7—KS-22473 Leveling Device

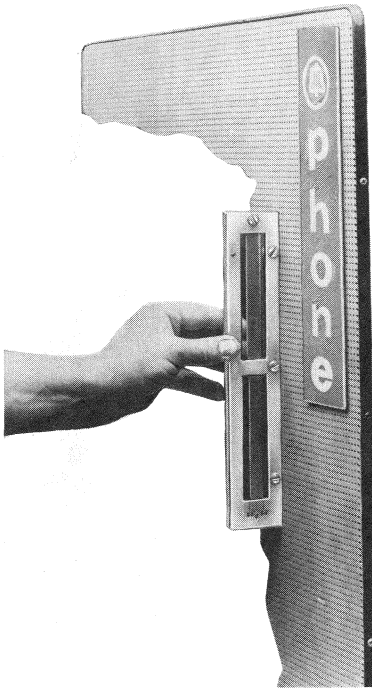

Fig. 8—KS-22473 Leveling Device Being Used to Check Wall and Backboard Alignment

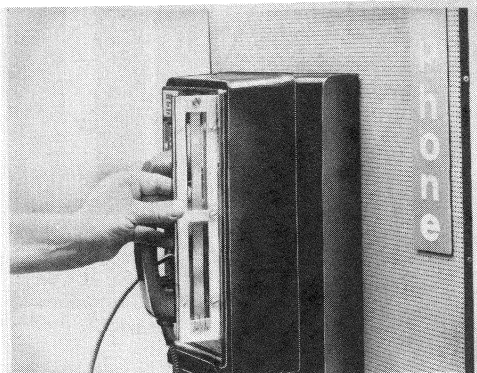

Fig. 9—KS-22473 Leveling Device Being Used to Check Front to Back Alignment



Fig. 10—KS-22473 Leveling Device Being Used to Check Side Alignment

- (4) Disconnect P1 by carefully pulling straight out as door is opened.

C. Chute-Totalizer

3.12 To remove chute-totalizer.

- (1) Disconnect P2.
- (2) Release chute locking lever.
- (3) Lift spring out of groove in chute.
- (4) Tilt top of chute forward and lift out.

3.13 To install chute-totalizer in set.

Caution: Before installing a chute in set, swing upper plate assembly open and clean off any foreign material adhering to chute magnets. Use a typewriter brush or equivalent.

TABLE I

METHOD OF DETERMINING
A VERTICAL SURFACE

SPIRIT LEVEL LENGTH	MAXIMUM ALLOWABLE DISTANCE OUT OF PLUMB
18 inches	15/32 inch
24 inches	5/8 inch
30 inches	25/32 inch
36 inches	15/16 inch

- (1) Place chute on locating pins at rear of hopper assembly, and back of housing (Fig. 13).

Note 1: Ensure that reject chute, return chute, and coin return assemblies line up properly.

Note 2: Ensure that IW wires are properly dressed behind totalizer cutout.

- (2) Place spring in groove on chute.
- (3) Lock spring in place by pushing chute locking lever down.
- (4) Connect totalizer plug P2 to J2.

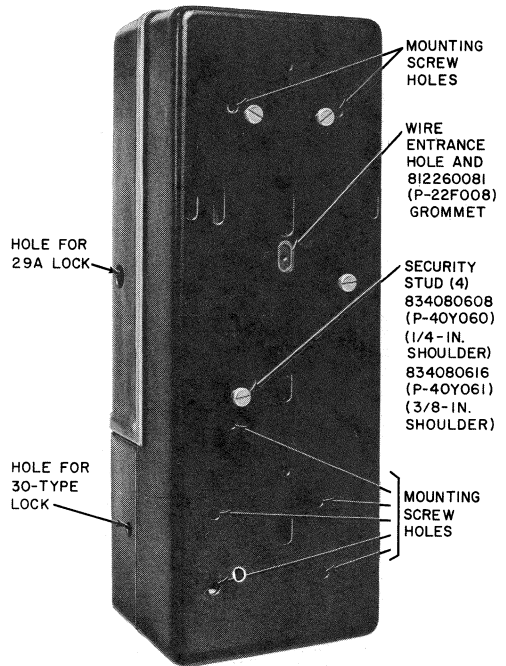

Fig. 11—Location of Mounting Screw Holes and Security Studs in 1-Type Set

- 3.14 To determine totalizer initial rate setting.



Use extreme care when checking initial rate or resetting totalizer. Avoid damaging pawl and spring pile-ups. Do not attempt to turn totalizer cam shaft in direction opposite to that shown in Fig. 14.

- (1) Remove chute-totalizer per paragraph 3.12.

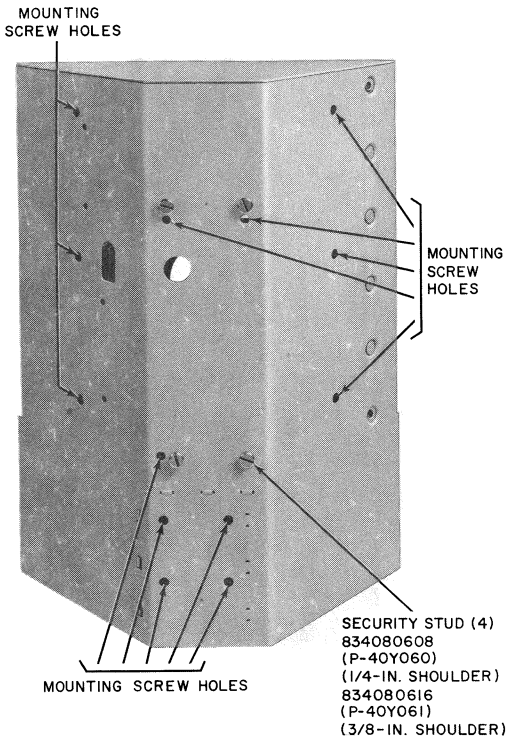

Fig. 12—Location of Mounting Screw Holes and Security Studs in 2-Type Set

- (2) Loosen retaining screw and remove transparent dust cover.
- (3) Rotate shaft in the proper direction (Fig. 14) until detent roller on detent wheel is positioned between the two black marks. This occurs at the same time T2 rests in depression in shaft. This position is called **home** position.
- (4) Release the reset latch by momentarily pressing downward on the armature of the RE relay (Fig. 14).
- (5) Slowly rotate shaft in proper direction, and count the steps until T1 springs operate (indicated by forward movement of reset latch).

- (6) Each step rotated from home position represents a 5-cent rate as shown in Table J.

3.15 To reset totalizer rate.

Note: Use two paper clips to reset the rate.

Increasing Rate (Fig. 15).

- (1) Rotate shaft in proper direction (Fig. 14) until it is in home position as described in paragraph 3.14(3).
- (2) Further rotate shaft approximately 10 steps until a tab on the T1 cam is accessible as shown in Fig. 15 and 16.
- (3) Insert a paper clip into one of the four holes indicated as hole 2 in center of shaft. Hold paper clip firmly so that shaft cannot move.

Caution: Do not push end of paper clip too far through shaft hole or it will damage insulation of coil located beneath shaft.

- (4) Position a second paper clip into the hole on T1 cam indicated as hole 1 and rotate cam in direction of the curved arrow as shown.



If hole 1 in T1 cam has been mutilated or clogged preventing use, place paper clip against tab as shown in Fig. 15 and push tab in direction of the straight arrow.

- (5) One step of rotation of the T1 cam in this direction increases the rate by 5 cents.
- (6) Check new initial rate setting per paragraph 3.14.

Decreasing Rate (Fig. 16)

- (7) Repeat steps (1) through (3).
- (8) Position a second paper clip into the hole on T1 cam indicated as hole 1 (Fig. 16) and rotate cam in direction of the curved arrow as shown.

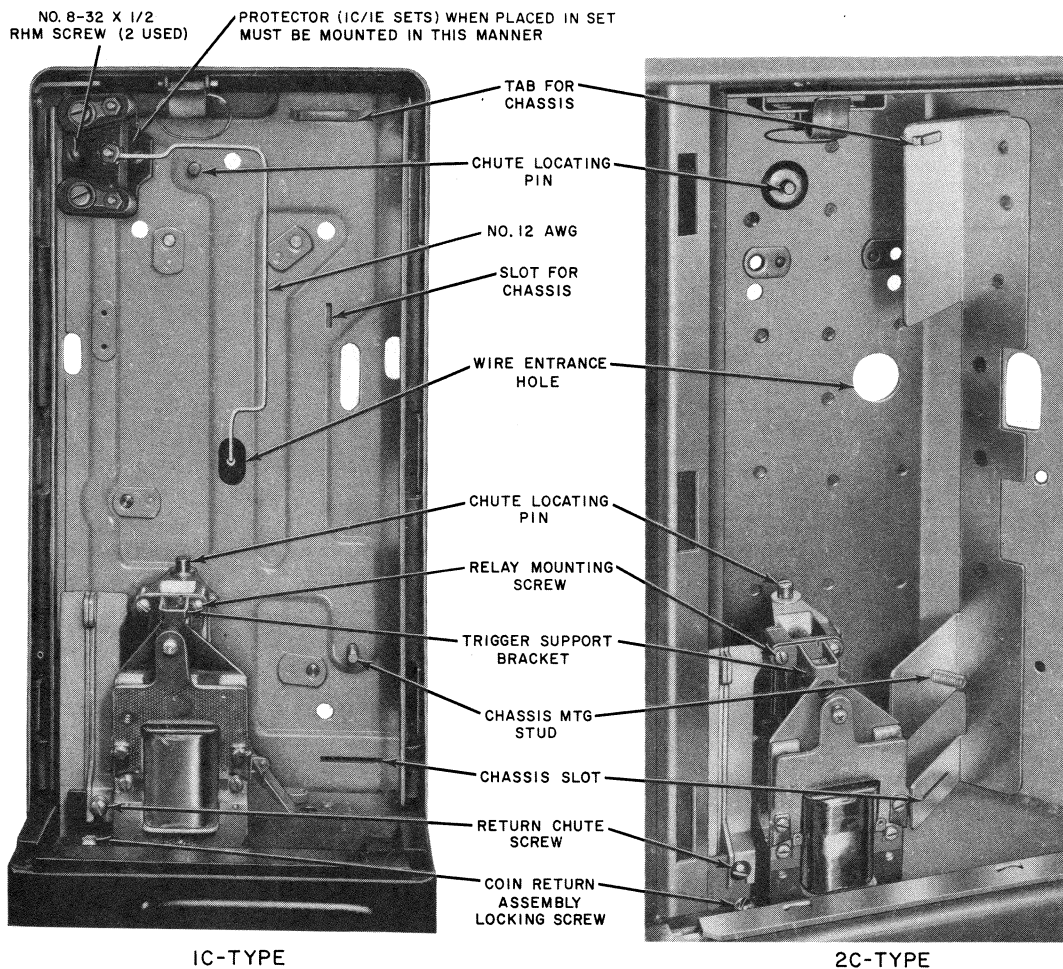

Fig. 13—Housing and Mounting Plate Assembly



If hole 1 in T1 cam has been mutilated or clogged preventing use, place paper clip against tab as shown in Fig. 16 and push tab in direction of the straight arrow.

- (9) One step of rotation of the T1 cam in this direction decreases the rate by 5 cents.
- (10) Check new initial rate setting as described in paragraph 3.14.

3.16 To remove totalizer from chute.



Do not damage totalizer arms when removing or replacing totalizer on chute or when returning damaged totalizers to service center. Do not turn screws that are sealed with glyptal. When returning totalizers or chutes to service center, reuse packing material from which the new item was removed.

TABLE J

METHOD FOR DETERMINING
INITIAL RATE *

NO. OF STEPS SHAFT IS ROTATED FROM HOME POSITION UNTIL T1 OPERATES	INDICATES FOLLOWING INITIAL RATE SETTING
1	5 cents
2	10 cents
3	15 cents
4	20 cents
5	25 cents
6	30 cents

*30 cents is not the maximum setting that can be obtained.

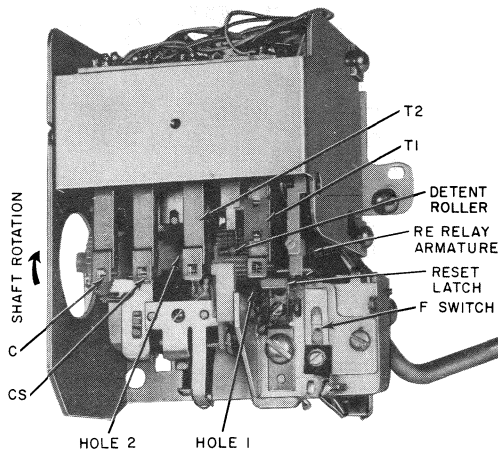

Fig. 14—Checking Totalizer Rate (Typical)

- (1) Unscrew three captive-type mounting screws from chute.
- (2) Carefully remove totalizer from chute.

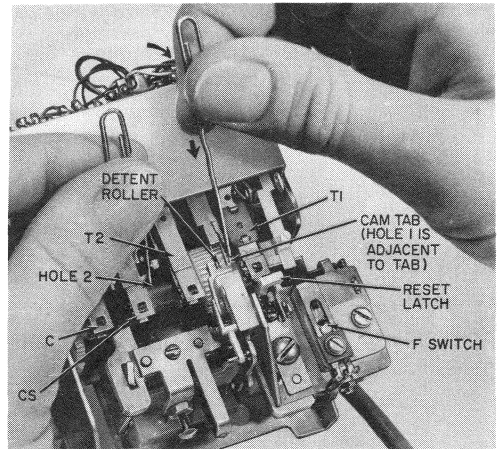

Fig. 15—Increasing Totalizer Rate (Typical)

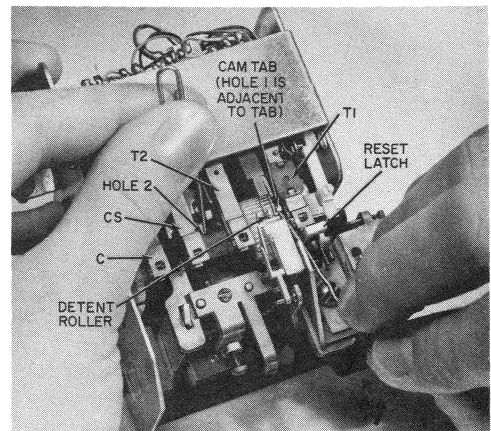

Fig. 16—Decreasing Totalizer Rate (Typical)

3.17 To install totalizer on chute.

- (1) Replace totalizer cover, if removed previously.
- (2) Line up the long guide pins on the totalizer with holes in the chute.

(3) Place totalizer on chute making sure that totalizer arms enter slots in chute. Be sure short guide pins on chute are in mating totalizer bracket holes.

(4) Tighten three captive-type mounting screws.

D. Coin Chassis

3.18 The 811554377 (P-15E437) single frequency (SF) coin chassis used in 1A/2A-type sets, can be replaced with an 840693634 dual frequency (DF) coin chassis (Fig. 17).

3.19 The 1A (SF) coin chassis used in 1C/2C-type sets can be replaced with a 31A (DF) coin chassis (Fig. 18).

3.20 The 30A (SF) coin chassis used in 1E-type sets can be replaced with a 30B (DF) coin chassis (Fig. 19).

3.21 DF oscillator-equipped coin chassis have the following features.

(a) Prior to August 1975, two screw terminals were furnished on the side of the oscillator. When these terminals are shorted, the oscillator is in the SF mode.

(b) All coin chassis and all sets containing them are shipped from the factory with a DF oscillator.

3.22 To remove coin chassis.

(1) Remove chute-totalizer per paragraph 3.12.

(2) Disconnect Tip, Ring, and Grd connections. Disconnect 12 AWG Grd strap if protector is mounted in set.

(3) On 1A/2A/1C/2C-type sets, disconnect (BK) and (Y) leads from coin relay and carefully pull leads through eyelet on side of hopper.

(4) On 1E1 set, disconnect (S-R) and (G) leads from coin hopper and carefully pull leads through eyelet on side of hopper.

(5) Loosen captive chassis mounting screw.

(6) Pull chassis assembly out at bottom and slide down to remove.

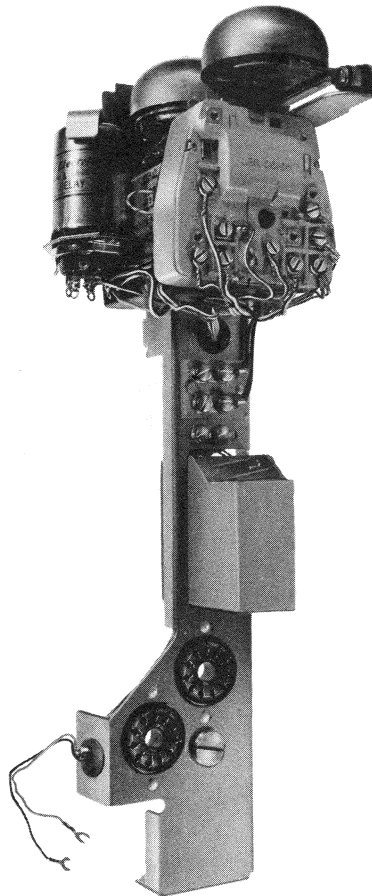

Fig. 17—840693634 Coin Chassis—For Use in 1A/2A-Type Sets

3.23 To install coin chassis.

(1) Slide chassis under tab (Fig. 13).

(2) Seat chassis tabs in slots.

(3) Tighten chassis mounting screw.

(4) On 1A/2A/1C/2C-type sets, thread (BK) and (Y) leads through eyelet on side of hopper.

- Connect (BK) lead to terminal 3 on coin relay

- Connect (Y) lead to terminal G on coin relay.



Fig. 18—31A Coin Chassis—For Use in 1C/2C-Type Sets

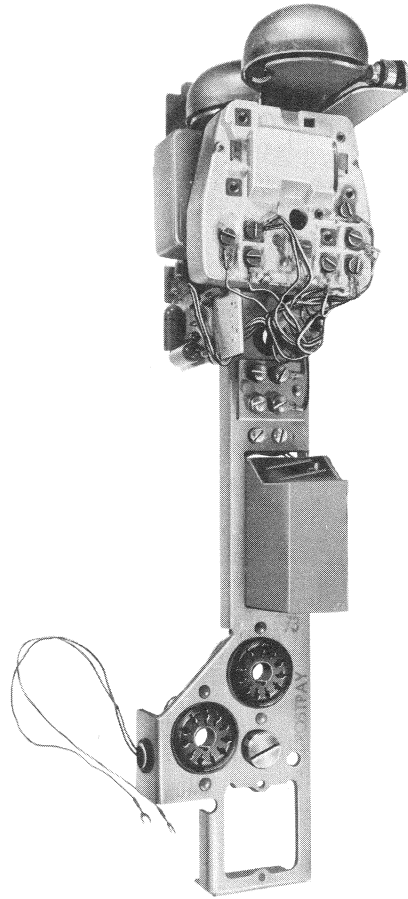

Fig. 19—30B Coin Chassis—For Use in 1E-Type Sets

- (5) On the 1E1 set, thread (S-R) and (G) leads through eyelet on side of hopper.
 - Connect (S-R) lead to left side of resistor on 50A hopper or terminal 15 on 51A hopper
 - Connect (G) lead to right side of resistor on 50A hopper or terminal 8 on 51A hopper.

- (6) On 1E3 set, tie the (S-R) and (G) leads together using a D-161488 connector. Ensure that connector is insulated.

- (7) Route IW wire up from grommet hole in backplate and to the right.
- (8) Connect Tip, Ring, and Grd leads, and if protector is mounted in set, 12 AWG Grd Strap.

E. Coin Receptacle (Cash Box)

3.24 Coin telephone sets manufactured prior to July 15, 1972 were equipped with a false floor to accommodate a 1B-type coin receptacle. They can be modified to accept a 1C-type receptacle as follows.

- (1) Remove cash compartment door.
- (2) Remove 1B-type coin receptacle.
 - Break spot welding at front tab
 - Pry out with large screwdriver or equivalent.
- (4) Install 1C-type coin receptacle.
- (5) Install cash compartment door.

F. Instruction Cards (1-Type Set)

3.25 Customer instruction cards are not furnished and must be procured locally.

3.26 To install card.

- (1) Loosen card locking setscrew (if provided) in faceplate using a No. 4 (.050) Allen wrench. Turn counterclockwise to loosen.
- (2) Push up with fingers (Fig. 20).
- (3) Snap card in place.
- (4) Ensure that card is seated properly in slot.
- (5) Tighten the No. 4-40 by 3/16-inch hex socket setscrew (840153381), if applicable, in faceplate (Fig. 21). Turn clockwise to tighten.



Do not over tighten setscrew after it becomes snug as this may bow the faceplate.

3.27 To remove card.

- (1) Loosen setscrew in faceplate, if provided, by turning it counterclockwise.
- (2) Push up with fingers.
- (3) Pry bottom out with small screwdriver or equivalent.



Fig. 20—Installing Instruction Cards in 1-Type Set (Typical)

G. 11A Card Holder

3.28 The 11A card holder (Fig. 22) is available as an auxiliary customer card frame which can be installed on 1-type coin telephone sets when they are mounted on 178A backboards.

3.29 The card holder can be installed without drilling, tapping, or defacing the set in any way.

3.30 Install as follows (Fig. 23).

- (1) Remove coin cover unit from set and set it aside.



Fig. 21—Securing Instruction Card (Typical)

- (2) Position small tab of rear bracket in wire cut-out of 178A backboard. Slide bracket to left as viewed from front.
- (3) Position gray plastic frame on front side of rear bracket and slide up.
- (4) Place instruction card (procured locally) and window in recessed area of plastic frame.
- (5) Mount front bracket over front edge of set housing and align screw holes of the two brackets.

Note: On older housings, an interference problem may be encountered with a flange on the front bracket. If this happens, cut the flange off the bracket.

- (6) Using a KS-19192, List 1 tool, secure with the two security screws furnished.

H. Instruction Cards (2-Type Set)

3.31 Instruction cards are not furnished and must be procured locally.

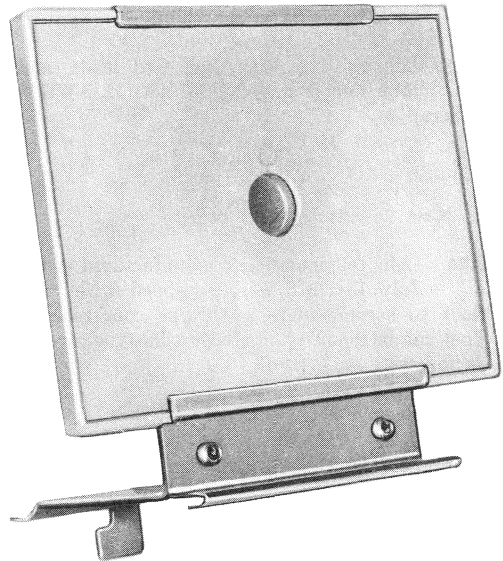

Fig. 22—11A Card Holder



There are two different methods for securing instruction cards in the 2-type sets.

(1) An 812360410 (P-23E041) card spring (MD) is provided in the bottom of each card slot on early 2-type sets. This spring puts pressure on bottom of card to hold it in place.

(2) A cam located in the top of each card slot on later 2-type sets holds the card secure. The cam is operated with a No. 4 (.050) Allen wrench.

3.32 To install card in a set equipped with a spring.

- (1) Push down with fingers (Fig. 24).
- (2) Snap card in place.
- (3) Ensure that card is seated properly.

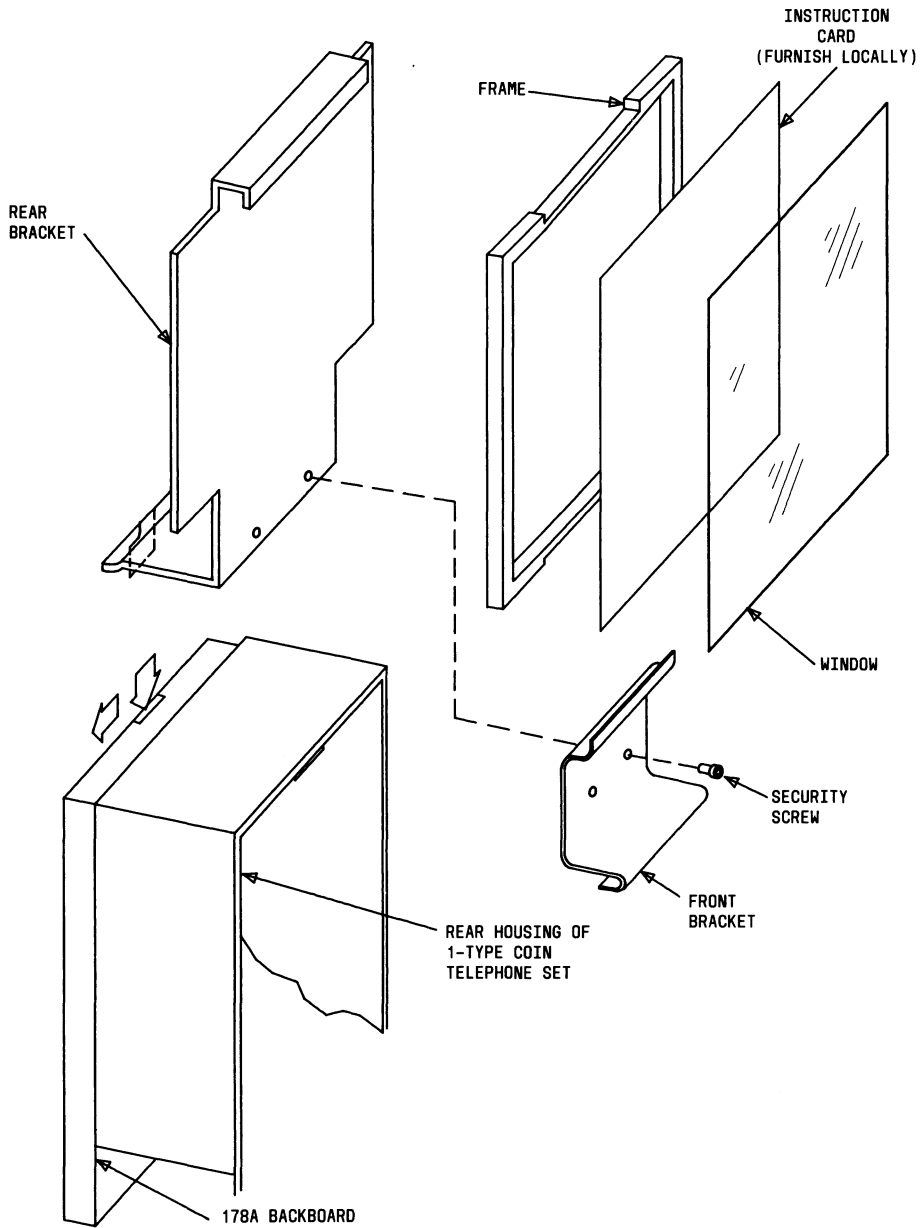

Fig. 23—Installation of 11A Card Holder

SECTION 506-410-400

3.33 To remove card from a set equipped with a spring.

- (1) Push down with fingers.
- (2) Pry out from top with small screwdriver or equivalent.

3.34 To install card in a set equipped with a cam.

- (1) Using a No. 4 (.050) Allen wrench, turn the cam until the low side is adjacent to card opening.
- (2) Push up with fingers (Fig. 25).
- (3) Snap card in place.
- (4) Ensure that card is seated properly in slot.
- (5) Secure card by turning cam 180 degrees, either clockwise or counterclockwise.

3.35 To remove a card from a set equipped with cam.

- (1) Turn cam 1/2 turn away from card using a No. 4 (.050) Allen wrench.
- (2) Push up with fingers.
- (3) Pry out from bottom with a small screwdriver or equivalent.

I. OUT-OF-SERVICE Sticker

3.36 A gummed OUT-OF-SERVICE sticker (Form E-4914) is available in books of five. Place over coin slot when required.

J. Number Card [8U (MD), 8W (MD), or 8WA Dial]

Note: The fingerwheel (840151872) is shipped assembled to the dial and must be removed to install number card. It is secured with a No. 4-40 setscrew (840158331).

3.37 To remove fingerwheel.

- (1) Refer to Fig. 26 use an Allen wrench and turn the setscrew in a clockwise direction until it clears fingerwheel.

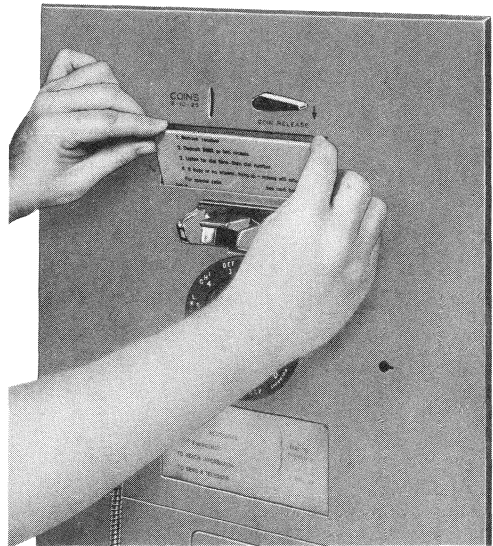

Fig. 24—Installing Instruction Card in 2-Type Set With 812360410 Card Spring

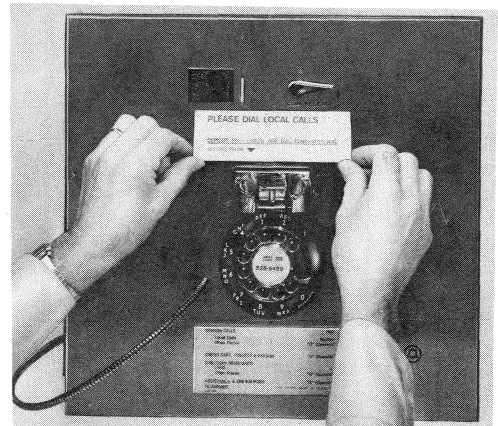

Fig. 25—Installing Instruction Card in 2-Type Set With Cam

Caution 1: When turning setscrew on 8WA, dial must be in the fully rundown position to prevent loosening the setscrew.

Caution 2: Do not turn setscrew beyond stopping point as this may damage screw or wrench.

- (2) Turn fingerwheel in a clockwise direction until operator hole is in the 9 position and lift off.

3.38 Install number card.

3.39 To install fingerwheel.

- (1) Ensure that setscrew is all the way in (clockwise).
- (2) Place fingerwheel on dial with operator hole over the 9 position.
- (3) Rotate fingerwheel counterclockwise until it is in its normal position.
- (4) Using an Allen wrench, turn the setscrew in a counterclockwise direction until the stop is reached (Fig. 26).

Caution: DO NOT OVERTIGHTEN SETSCREW

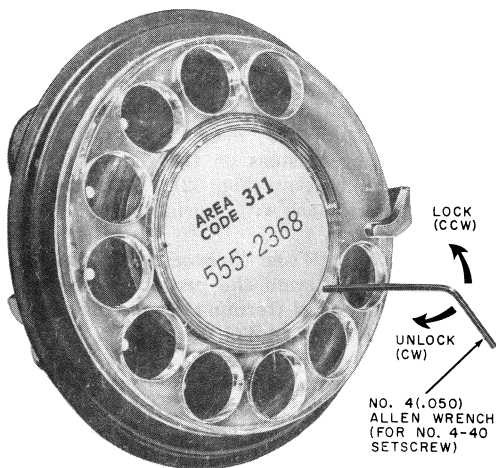

Fig. 26—Installing Fingerwheel on 8U (MD), 8W (MD), or 8WA Dial

K. Number Card (TOUCH-TONE Set)

3.40 The number card shall be furnished locally.

3.41 A card holder bracket, window, and two nuts (Fig. 27) are packaged separately and shipped from the factory in the cash compartment.

3.42 Install number card as follows.

- (1) Remove dial housing.
- (2) Insert window in faceplate from rear (Fig. 28).
- (3) Insert number card in window (Fig. 28).
- (4) Secure window and number card using the card holder bracket and two nuts (Fig. 29).

Note: Thread-forming nuts are used on 1-type sets and hex nuts are used on 2-type sets.

- (5) Install dial housing.

Note: Ensure that the four dial housing mounting screws are tight to prevent dial housing from becoming loose due to vibration.



The window, bracket, and nuts are available in a kit for maintenance purposes.

- D-180567 kit for a 2-type set
- D-180655 kit for a 1-type set.

WIRING AND GROUNDING

3.43 Provide individual signaling ground for each station. Select and place wire in accordance with Section 461-200-100. Provide individual and multiple station grounding in accordance with Sections 460-100-400 and 506-100-100. Refer to Fig. 30 for special protection requirements and Section 508-100-100 to check for proper bonding and grounding of telephone enclosure commercial power.

3.44 Feed inside wire straight up from entrance hole approximately 2 inches, then across to TB1 on the coin chassis.

3.45 Dress inside wire to right side of coin chassis.

SECTION 506-410-400

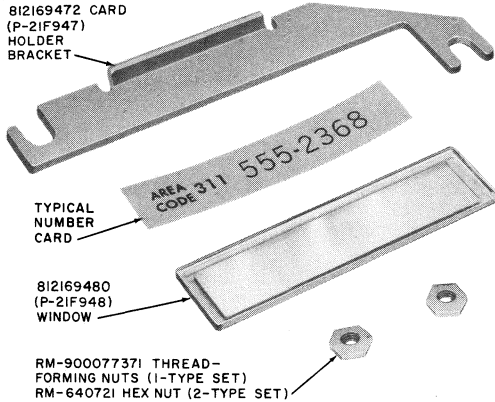

Fig. 27—Number Card and Associated Hardware for TOUCH-TONE Set



Fig. 29—Card Holder Bracket Installed in TOUCH-TONE Set

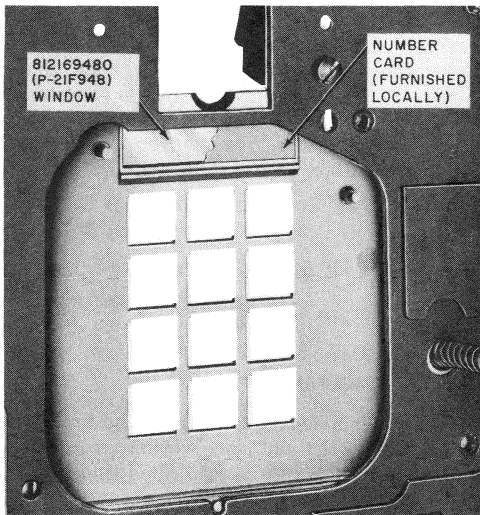

Fig. 28—Window and Number Card Installed in TOUCH-TONE Set

- 3.46 Conceal wiring near telephone. Use approved molding or tubing if necessary.
- 3.47 Locate protectors (123E1A gas tube, or 123A1A carbon-block), connecting blocks, etc, where they will be inaccessible to person using coin telephone set.
- 3.48 For outdoor installations where drop comes directly into set, a protector can be installed inside some sets as follows.

- (1) Install the protector inside a 1C- or 1E-type set as shown in Fig. 13 using two 802056077 (No. 8-32 by 1/2-inch) RHM screw provided locally.
- (2) Install the protector inside a 2A- or 2C-type set on a 7A clip (Fig. 31). Push the 7A clip, with protector, in the set so its spring loaded flange fastens on the right leg of the chute lock bracket (Fig. 32). Dress leads to avoid interference with moving parts.

Caution: When protector is mounted inside set, bond the protector ground to signal ground (terminal G on coin chassis) with No. 12 AWG wire (Fig. 30).



After installation has been completed, refer to Part 4 and verify that the coin telephone set is operating correctly and that information plate agrees with mode of service. Also verify that

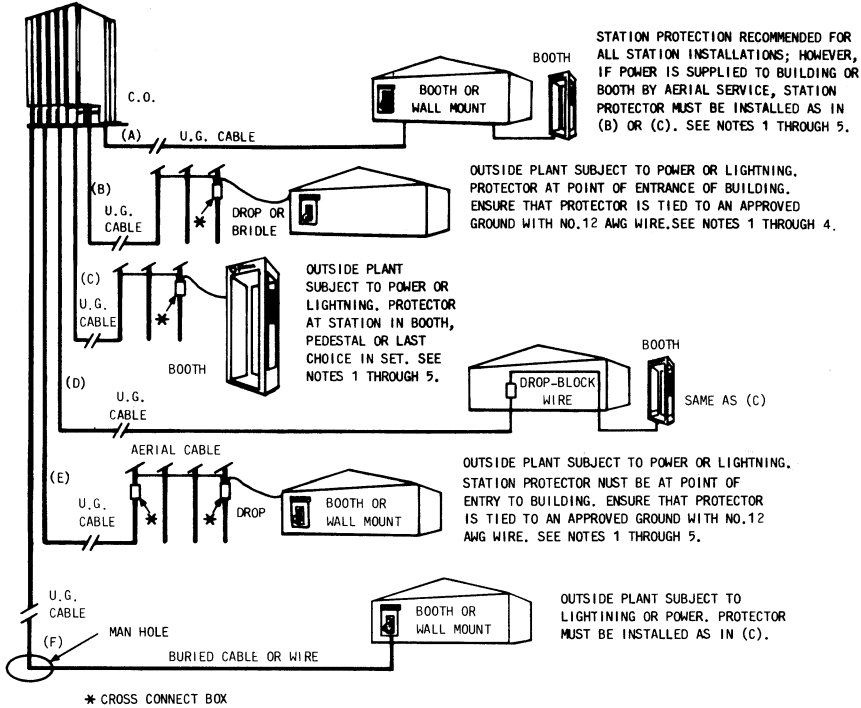

NOTES:

1. FOR ADDITIONAL INFORMATION ON STATION PROTECTOR AND SIGNALING GROUNDS, REFER TO SECTION 460-100-400.
2. HOUSINGS OF ALL OUTSIDE STATIONS MUST BE GROUNDED, IF SET IS NOT MOUNTED IN A GROUNDED ENCLOSURE, RUN A NO. 12 AWG WIRE FROM STATION TO NEAREST APPROVED GROUND.
3. CARBON BLOCKS THAT BREAK DOWN PREMATURELY CAN CAUSE FAILURES OF COIN COLLECT OR REFUND. CARBON BLOCKS SHOULD BE REPLACED BY GAS TUBE PROTECTORS (123E1A) OR 1181A PROTECTOR UNITS IN 123-TYPE PROTECTOR BASE. SEE SECTION 506-100-100.
4. WHEN THE PROTECTOR IS MOUNTED IN AN ENCLOSURE SUCH AS A BOOTH OR SHELF, BOND THE ENCLOSURE AND PROTECTOR GROUND TOGETHER WITH NO LESS THAN NO. 12 AWG WIRE. SEE SECTION 508-100-100.
5. WHEN PROTECTOR IS MOUNTED INSIDE SET, CONNECT WIRING PER THIS SKETCH.

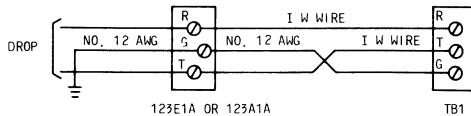

Fig. 30—Special Protection Requirements

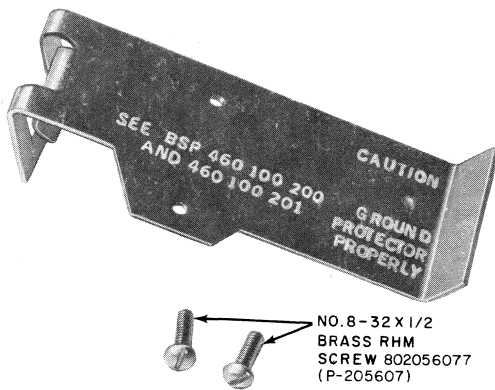

Fig. 31—7A Clip For Mounting 123A1A (MD) or 123E1A Protector and 840362024 Capacitor Board Assembly in Panel Set

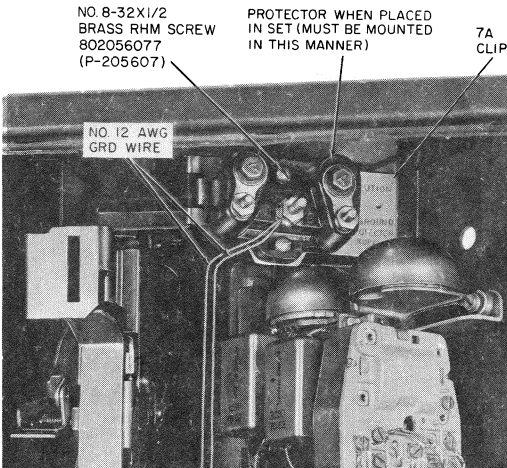

Fig. 32—123A1A (MD) or 123E1A Protector Installed in Panel Set

entrance stop is adjusted properly to prevent rubbing of parts.

4. OPERATION TESTS AND TROUBLE ANALYSIS



On trouble reports of coins collected or returned in error, try to obtain area code and telephone number of called party to facilitate tracing trouble in central office. Tests specified in Tables K, L, M, N, or O shall be used to ensure proper set operation on installation and maintenance visits. For additional tests relating to general coin service, refer to Section 506-900-503 or the Public Services Maintenance Check Booklet.

4.01 Apparatus Required:

- KS-20950, List 2 cover parking tool (Fig. 33)—1-type set only, refer to note under Table F.

Note: A P11C test cord (Fig. 34) may be used with 1-type sets in lieu of the cover parking tool, and on all 2-type sets.

- Coins: 1 penny, 2 nickels, 1 dime, 2 quarters
- KS-14995, List 3 Coin Trap and Vane Release Toll (Fig. 35)
- 146B Bias Margin Gauge (Fig. 36).

4.02 Table K includes following trouble analysis tests for *Coin-First Service*.

- Totalizer and Coin Relay Operation (On-Hook)
- Totalizer Operation (Off-Hook)
- Dial Shorting Test
- Trap and Vane Release Test
- Coin Relay Bias Margin Test
- Testing with ACTS.

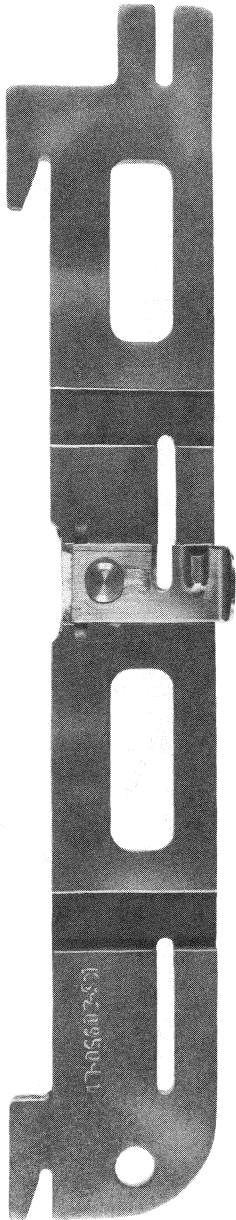

Fig. 33—KS-20950, List 2 Cover Parking Tool

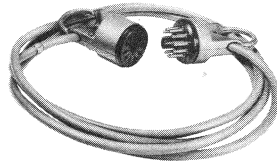

Fig. 34—P11C Test Cord

4.03 Table L includes the following trouble analysis test for *Dial-Tone-First Service*:

- Dial Tone Test
- Totalizer and Coin Relay Operation
- Trap and Vane Release Test
- Coin Relay Bias Margin Test
- Testing with ACTS.

4.04 Table M includes trouble analysis test for *Dial Postpay Service* where ACTS is not available.

4.05 Table N includes trouble analysis test for Dial Postpay Service where ACTS *is* available.

4.06 Table O includes trouble analysis test for *Manual Postpay Service*.

4.07 Refer to Table P for operate values of coin relay.

MULTISLOT COIN COLLECTOR MAINTENANCE	SINGLE SLOT COIN TELEPHONE SET MAINTENANCE
INSPECT EXTERIOR Handset, Cords, Dial Cards: Instruction & No. Coin Release, Return Bucket	INSPECT EXTERIOR Handset, Cords, Dial Cards: Instruction & No. Coin Release, Return Bucket
COIN TESTS 5c, 10c, 25c Dial Tone, Coin Return Trouble Analysis	COIN TESTS 5c, 10c, 25c Dial Tone Coin Return On-Hook Coin Return Trouble Analysis
INSPECT INTERIOR Gauge, Connections Security Fasteners Housing Contacts	INSPECT INTERIOR Chute Assembly Connections, Plugs Switchhook
COIN CHUTE Dirt, Corrosion	COIN RELAY Bias Margin, Trap, Vane
SWITCHHOOK Spring Pileups	RESISTANCE TESTS Loop, Ground
COIN RELAY Bias Margin, Trap, Vane	STATION WIRING Ground Connections Protector Booth Ground
RESISTANCE TESTS Loop, Ground	OPERATIONAL TESTS Coins Operator, Ring-Back
STATION WIRING Ground Connections Protector Booth Ground	INSPECT BOOTH Glass, Door, Lights Blower, Directories
OPERATIONAL TESTS Coins Operator, Ring-Back	KS-14995 L3 TOOL
INSPECT BOOTH Glass, Door, Lights Blower, Directories	

Fig. 35—KS-14995, List 3 Tool

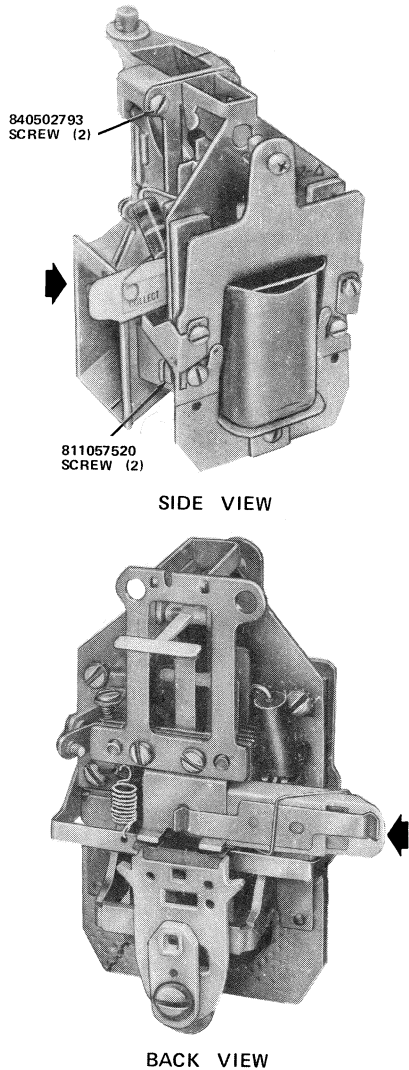

Fig. 36—Bias Margin Gauge in Position for Collect Test

TABLE K
TROUBLE ANALYSIS – 1A/1C- AND 2A/2C-TYPE SETS
COIN-FIRST

STEP	ACTION	VERIFICATION	FAILURE	POSSIBLE CAUSE	REMEDIAL ACTION
Preparation For All Tests Except Trap and Vane Release					
1	Invert handset on switchhook (Fig. 37) (1-type only) to prevent cord from pushing handset off switchhook when cover is set down				
2	For a 1-type set: Remove coin cover unit and hang it on a KS-20950, List 2 cover parking tool (Fig. 33). If parking tool is not available, or cannot be used with the station, disconnect P1, place coin cover unit on a firm level surface, and connect a P11C cord between P1 and J1 of coin chassis.				
3	For a 2-type set: Open door and faceplate assembly and connect a P11C cord (Fig. 34) between P1 and J1.				
Totalizer and Coin Relay Operation (On-Hook)					
<i>Note:</i> On repeated "No Dial Tone" reports, a totalizer current flow test should be performed in addition to the following.					
4	Deposit penny and operate coin release mechanism	Coin is returned	Coin does not return	Blocked coin chute Defective coin release mechanism	Clear Replace defective linkage
5	Deposit quarter in chute	Coin relay refunds coin	Coin does not return or coin is collected	Blocked coin chute	Clear
				Tip and ring reversed or coin trunk trouble	Reconnect or refer to testdesk
				P1 and P2 reversed	Reconnect properly
				Totalizer in DTF mode (1C/2C set only)	Switch to CF mode
			TB3 not wired correctly (1C/2C set only)	Wire correctly	

TABLE K (Contd)
TROUBLE ANALYSIS - 1A/1C- AND 2A/2C-TYPE SETS
COIN-FIRST

STEP	ACTION	VERIFICATION	FAILURE	POSSIBLE CAUSE	REMEDIAL ACTION
5 (Contd)				Traffic overload	Wait for refund pulse
				Coin jam in hopper	Clear jam
				Full coin receptacle	Level coins and notify coin collection department
				Coin relay HT contacts not making	Clean contacts or replace coin relay
				Switchhook transfer contacts SH1 (NC) or SH3 (NC) not making	Clean contacts or replaces coin dial unit
				Switchhook contacts SH2 and SH4 not breaking	Adjust contacts or replace coin dial unit
				Defective totalizer	Replace defective apparatus
				Defective A relay	
				Defective handset	
				Defective dial TOUCH-TONE only)	
6	Deposit nickel	Nickel returned	Nickel does not return	Defective wiring in dial housing or chassis	Wire properly
				Defective coin relay	
				Coin relay improperly wired	
				Switchhook transfer contacts SH1 (NC) or SH3 (NC) not making	
7	Go off hook and deposit nickel in coin chute	No dial tone	Dial tone heard	TB2 and wired correctly	Wire correctly
				Defective wiring in dial housing or chassis	Replace defective apparatus
				Traffic overload	Wait for refund pulse
Totalizer Operation (Off-Hook)					
7	Go off hook and deposit nickel in coin chute	No dial tone	Dial tone heard	T1 contacts remain latched after refund	Replace totalizer

TABLE K (Contd)
TROUBLE ANALYSIS – 1A/1C- AND 2A/2C-TYPE SETS
COIN-FIRST

STEP	ACTION	VERIFICATION	FAILURE	POSSIBLE CAUSE	REMEDIAL ACTION
7 (Contd)				Switchhook transfer contacts SH3 (NC) not breaking (rotary dial sets only)	Replace coin dial unit
				Defective chassis or chassis wiring	Replace chassis or correct wiring
				Defective wiring in coin dial unit	Replace coin dial unit
8	Deposit additional coins up to initial rate	Dial tone is heard	No dial tone, Reduced level or intermittent dial tone	Traffic overload	Wait for dial tone
				Defective handset	Replace handset
				Switchhook contacts SH3 (NO) or SH2 and SH4 (NO) not making	Clean contacts or replace coin dial unit
				Switchhook transfer contacts SH1 (NO) not making	Clean contacts or replace coin dial unit
				Totalizer set for more than initial rate	Reset totalizer rate
				Conduct current flow test on totalizer and measure loop and ground resistance with test desk	Take action according to test board results
				T1 contacts (NO) not making	Replace totalizer
				F contacts (NC) not making	Replace totalizer
				Defective wiring in coin dial unit	Replace coin dial unit
				Defective dial	Replace defective apparatus
9	Dial any digit but "0" or "1"	Dial tone breaks	Cannot break dial tone	Defective chassis	Replace defective apparatus
				Defective totalizer	Replace totalizer
				Totalizer transfer contacts T2 (NC) not making (totalizer steps continuously)	Replace totalizer
				Totalizer contacts T1 not latching	Replace totalizer
				Defective dial	Replace totalizer
				Defective handset (TOUCH-TONE only)	Replace defective apparatus
				Defective wiring in chassis, or coin dial unit	Replace defective apparatus

TABLE K (Contd)
TROUBLE ANALYSIS – 1A/1C- AND 2A/2C-TYPE SETS
COIN-FIRST

STEP	ACTION	VERIFICATION	FAILURE	POSSIBLE CAUSE	REMEDIAL ACTION
9 (Contd)		Coins not returned	Coins returned	Defective dial	Replace dial
10	Go on hook	Coins returned	Coins not returned	Traffic overload	Wait for refund pulse
				Coin trunk trouble	Refer to testdesk
11	Go off hook and deposit initial rate	Dial tone heard	No dial tone	Defective totalizer	Replace totalizer
				Traffic overload	Wait for dial tone
12	Dial any digit but "0" or "1"	Dial tone breaks	Cannot break dial tone	Defective totalizer	Replace totalizer
13	Go on hook	Coins returned	Coins not returned	Traffic overload	Wait for refund pulse
				Coin trunk trouble	Refer to testdesk
	Dial Shorting Test				
14	Remove coin relay dust cover. Lift handset and operate hopper trigger by hand	Dial tone heard	No dial tone	Traffic overload	Wait for dial tone
15	Dial any digit but "0" or "1"	Dial tone remains after dialing	Dial tone breaks	Totalizer transfer contacts T1 (NC) not making	Replace totalizer
				Defective chassis	Replace chassis
16	Deposit nickel	Dial tone remains after deposit	Line drops off. Coin returned	Defective chassis	Replace chassis
				Defective A relay (1A/2A only)	Replace A relay
17	Hang up handset	Nickel returns	Nickel does not return	Traffic overload	Wait for coin return pulse
				Defective coin trunk	Refer to testdesk
	Trap and Vane Release Test				
18	Remove chute — totalizer from set				
19	Remove coin relay dust cover				

TABLE K (Contd)
TROUBLE ANALYSIS – 1A/1C- AND 2A/2C-TYPE SETS
COIN-FIRST

STEP	ACTION	VERIFICATION	FAILURE	POSSIBLE CAUSE	REMEDIAL ACTION
	<i>Caution: Tilt selector card by pressing down on one of the ears before manually operating the coin relay. This avoids jamming selector card and cam engaging surfaces.</i>				
20	Press down on left ear of selector card and manually operate coin relay armature to its full extent of travel	Coin vane moves to collect (left) position; coin trap moves downward			
21	With armature fully operated, insert KS-14995, L3 tool into hopper to operate trap to the limit of its travel (Fig. 38)				
22	Release armature and slowly withdraw tool	Armature, trap, and vane should return to nonoperated position and trap should lock	Armature, trap, or vane does not return to its normal position Vane does not restore properly	Relay could be binding Vane binds Vane broken	Loosen mounting screws and re-align relay; tighten screws Replace relay Remove coin relay from hopper and free vane Replace vane per Section 506-100-110
23	Press down on right ear of selector card and manually operate coin relay armature to its full extent of travel	Coin vane moves to refund (right) position. Coin trap moves downward	Trap does not operate, restore or lock properly	Trap broken Trap spring bent or broken Trap lever broken Trap pin bent or broken	Replace defective apparatus

TABLE K (Contd)
TROUBLE ANALYSIS – 1A/1C- AND 2A/2C-TYPE SETS
COIN-FIRST

STEP	ACTION	VERIFICATION	FAILURE	POSSIBLE CAUSE	REMEDIAL ACTION
24	With armature fully operated, insert KS-14995, L3 tool into hopper to operate trap to the limit of its travel (Fig. 38)				
25	Release armature and slowly withdraw tool	Same as 22	Same as 22	Same as 22	Same as 22
26	Install dust cover				
27	Install chute — totalizer				
Coin Relay Bias Margin Test					
Note: Make this test when coin relay fails to operate properly or on repeated reports of coins don't return.					
28	Remove coin relay dust cover				
29	Go off hook, obtain dial tone, call testdesk and request bias margin test. (Use central office test circuit where available)				
30	Slip 146B bias margin gauge over left polepiece extension arm from left side of coin relay (Fig. 36)				
31	Request testdesk to apply central office collect (or return) voltage as indicated in the lower left corner of gauge	Relay operates to collect (or return) coins as indicated in lower left corner of gauge	Relay does not operate properly	Defective coin relay	Replaces coin relay
32	Reverse the 146B bias margin gauge by turning it around on the same polepiece extension arm				

TABLE K (Contd)
TROUBLE ANALYSIS – 1A/1C- AND 2A/2C-TYPE SETS
COIN-FIRST

STEP	ACTION	VERIFICATION	FAILURE	POSSIBLE CAUSE	REMEDIAL ACTION
33	Request testdesk to collect (or refund) as indicated on the left corner of gauge	Relay operates to collect (or return) coins as indicated in lower corner of gauge	Relay does not operate properly	Defective coin relay	Replace coin relay
34	Remove 146B gauge and request testdesk to perform coin relay current flow test				
35	Go on-hook				
36	Install dust cover				
Returning Set To Normal Operation where ACTS is not Available					
37	Call operator. Deposit nickel, dime, and quarter	Coins identified by operator	Improper coin tones	Defective totalizer Defective chassis	Replace totalizer Replace chassis
38	Listen for coin tones in handset as coins are deposited	No coin tones or low level coin tones heard in handset	Loud coin tones heard in handset	Defective chassis	Replace chassis
39	Request operator to return coins	Coins returned	Coins not returned	Nonstation trouble	Repeat request, and if failure reoccurs refer to test desk
40	Request operator to call. Go on hook. Wait for incoming ring.	Ringer operates at maximum volume	No ringback or low volume	Defective ringer or leads Ringer out of adjustment Open ringer capacitor in network Improper line assignment Nonstation trouble	Replace ringer Adjust Replace chassis Verify and correct Refer to test desk
41	Call the dial test number and verify all TOUCH-TONE frequencies (if applicable)				

TABLE K (Contd)
TROUBLE ANALYSIS – 1A/1C- AND 2A/2C-TYPE SETS
COIN-FIRST

STEP	ACTION	VERIFICATION	FAILURE	POSSIBLE CAUSE	REMEDIAL ACTION
Returning Set to Normal Operation where ACTS is Available					
42	Dial the ACTS test line (Number supplied by local supervision) <i>Note:</i> Initial rate deposit is required in coin first service	Coin(s) returned (coin first only). Announcement "COIN TEST" is heard. After one second silence, announcement "PLEASE DEPOSIT NICKEL" is heard	Deposited coin(s) don't return. Announcement not heard. <i>Note:</i> If coin test line is busy, reorder tone will be heard.	Nonstation trouble	Refer to testdesk
43	Deposit a nickel <i>Note:</i> Dime and quarter are verified in the same manner.	Test line identifies coin by announcement "NICKEL" <i>Note:</i> Dime and quarter are verified in the same manner as a nickel.	Announcement "TIMING ERROR" is heard. <i>Note:</i> If retest is desired, do not hang up. After 1/2 second "PLEASE DEPOSIT NICKEL" announcement will be repeated.	Defective totalizer	Replace defective apparatus. (If trouble persists, refer to testdesk for loop analysis ie, bridge tap or excessive loading.)
			No immediate announcement. <i>Note:</i> Coin signals of improper level and/or frequency are not recognized and are treated as if no coin is deposited. If no coin is detected within 6 seconds after original request for deposit, request will be repeated for retest. If no coin is detected after three additional requests, announcement "TEST HAS ENDED" will be made and test time will disconnect	Defective Chassis	

TABLE K (Contd)
TROUBLE ANALYSIS – 1A/1C- AND 2A/2C-TYPE SETS
COIN-FIRST

STEP	ACTION	VERIFICATION	FAILURE	POSSIBLE CAUSE	REMEDIAL ACTION
43 (Contd)			Test line recognizes a coin other than that deposited. <i>Note:</i> This can occur during the basic sequence if improper coin is deposited or if totalizer generates an improper signal. Test line identifies coin as detected, returns coin, then repeats previous coin request announcement.	Defective totalizer	
44	Listen for coin tones in handset as coins are deposited	Low coin tones heard in handset	Loud coin tones heard in handset	Defective chassis	Replace chassis
45 (Optional)	Deposit additional coins in any sequence if desired; however, a two minute over-all time limit is placed on each test call. If this is exceeded, an announcement "TEST HAS ENDED" will be heard, a coin return signal will be generated, and the connection will be broken	Test line will identify coins as deposited	Same as Step 43	Same as Step 43	Same as Step 43
46	Hang up handset	Coins return	Coins do not return	Nonstation trouble	Refer to test desk
47	Dial the station under test from a nearby telephone or call operator and request operator to call back. Go on hook. Wait for incoming call.	Ringer operates at maximum volume	No ringback or low volume	Defective ringer or leads Ringer out of adjustment Open ringer capacitor in network Improper line assignment Nonstation trouble	Replace ringer Adjust Replace chassis Verify and correct Refer to test desk

TABLE L
TROUBLE ANALYSIS - 1C- AND 2C-TYPE SETS
DIAL-TONE-FIRST

STEP	ACTION	VERIFICATION	FAILURE	POSSIBLE CAUSE	REMEDIAL ACTION
Preparation For All Tests Except Trap and Vane Release					
1	Invert handset on switchhook (Fig. 37) (1-type only) to prevent armored cord from pushing handset off hook when cover is set down.				
2	For 1-type set: Remove coin cover unit and hang it on a KS-20950, List 2 cover parking tool (Fig. 33). If parking tool is not available, or cannot be used at the station, disconnect P1, place coin cover unit on a firm level surface, and connect a P11C cord between plug P1 and jack J1 of the coin chassis.				
3	For 2-type set: Open door and faceplate assembly. Connect a P11C cord between P1 and J1.				
Dial Tone Test					
4	Go off hook	Dial tone received	No dial tone	Defective handset Traffic overload Switchhook contacts SH1 not making P1 and P2 reversed Totalizer in CF mode TB2 not wired correctly TB3 not wired correctly	Replace handset Wait Clean contacts or replace coin dial unit Reconnect properly Switch to DTF mode Wire correctly Wire correctly

TABLE L (Contd)
TROUBLE ANALYSIS – 1C-AND 2C-TYPE SETS
DIAL-TONE-FIRST

STEP	ACTION	VERIFICATION	FAILURE	POSSIBLE CAUSE	REMEDIAL ACTION
4 (Contd)				Defective totalizer Defective wiring in chassis, or coin dial unit Nonstation trouble	Replace totalizer Replace defective apparatus Refer to testdesk
Totalizer and Coin Relay Operation					
5	Deposit quarter	Quarter does not return	Quarter falls in return bucket	TB3 not wired correctly Chute path blocked Defective totalizer Defective chassis	Wire correctly Clear Replace defective apparatus
6	Depress switchhook	Quarter returned	Quarter does not return	Switchhook contacts not breaking Defective coin trunk Defective totalizer Defective chassis Defective coin relay	Replace coin dial unit Refer to testdesk Replace defective apparatus
7	Deposit nickel less than initial rate. Dial a number that requires initial rate.	Dial tone breaks Recording states that insufficient deposit was made	Dial tone does not break Recording not heard	Defective dial Tip, ring, or grd reversed Defective chassis Initial rate set incorrectly TB3 not wired correctly Totalizer contacts TI making with less than initial rate deposited Traffic overload Nonstation trouble	Replace dial Wire correctly Replace chassis Reset the rate Wire correctly Reset totalizer rate or replace totalizer Wait and repeat test Refer to testdesk

TABLE L (Contd)
TROUBLE ANALYSIS – 1C- AND 2C-TYPE SETS
DIAL-TONE-FIRST

STEP	ACTION	VERIFICATION	FAILURE	POSSIBLE CAUSE	REMEDIAL ACTION
8	Depress switchhook	Coin returned <i>Note:</i> Coin may have already returned on announcement trunk seizure	Coin not returned	Switchhook contacts not breaking	Replace coin dial unit
				Defective coin trunk	Refer to testdesk
				Traffic overload	
				Nonstation trouble	
				Defective totalizer	
9	Go off-hook deposit initial rate, dial a number that requires a deposit <i>Note:</i> Ensure that called number will not be answered.	Ringing tone heard in handset	Insufficient deposit recording heard	Defective T1 or F contacts in totalizer	Reset rate
				Defective chassis	Replace defective apparatus
				Switchhook SH3 (NO) not making	Clean contact, replace coin dial unit
				TB3 not wired correctly	Wire correctly
				Defective coin trunk	Refer to testdesk
				Nonstation trouble	
10	Go on-hook	Coins returned	Coins not returned		
11	Deposit penny and operate coin release lever	Penny returned	Coin does not return	Defective coin chute	Clear
				Defective coin release mechanism	Replace defective linkage

TABLE L (Contd)
TROUBLE ANALYSIS – 1C- AND 2C-TYPE SETS
DIAL-TONE-FIRST

STEP	ACTION	VERIFICATION	FAILURE	POSSIBLE CAUSE	REMEDIAL ACTION
Trap and Vane Release Test					
<i>Note:</i> Refer to Table K					
Coin Relay Bias Margin Test					
<i>Note:</i> Refer to Table K					
Returning Set To Normal Operation where ACTS is not Available					
12	Call operator. Deposit nickel, dime, and quarter	Coins identified by operator	Improper coin tone signals	Defective totalizer	Replace defective apparatus
13	Listen for coin tones in handset as coins are deposited	Low coin tones heard in handset	Loud coin tones heard in handset	Defective chassis	
14	Request operator to return coins	Coins returned	Coins not returned	Nonstation trouble	Repeat request, and if failure reoccurs refer to testdesk
15	Request operator to ring back (hang up)	Ringer operates at maximum volume	No ringback or low volume	Defective ringer or leads	Replace ringer
				Ringer out of adjustment	Adjust
16	Call the dial test number and verify all TOUCH-TONE frequencies (if applicable)			Open ringer capacitor in network	Replace chassis
				Improper line assignment	Refer to testdesk
Returning Set to Normal Operation where ACTS is Available					
17	Dial the ACTS test line (Number supplied by local supervision).	Announcement "COIN TEST" is heard. After one second silence, announcement "PLEASE DEPOSIT NICKEL" is heard.	Announcement not heard. <i>Note:</i> If coin test line is busy, reorder tone will be heard.	Nonstation trouble	Refer to testdesk

TABLE L (Contd)
TROUBLE ANALYSIS – 1C- AND 2C-TYPE SETS
DIAL-TONE-FIRST

STEP	ACTION	VERIFICATION	FAILURE	POSSIBLE CAUSE	REMEDIAL ACTION
18	Deposit a nickel <i>Note:</i> Dime and quarter are verified in the same manner.	Test line identifies coin by announcement "NICKEL". <i>Note:</i> Dime and quarter are verified in the same manner as a nickel.	Announcement "TIMING ERROR" is heard. <i>Note:</i> If retest is desired, do not hang up. After 1/2 second, "PLEASE DEPOSIT NICKEL" announcement will be repeated.	Defective totalizer	Replace defective apparatus (If trouble persists, refer to testdesk for loop analysis ie, bridge tap or excessive loading).
			No immediate announcement. <i>Note:</i> Coin signals of improper level and/or frequency are not recognized and are treated as if no coin was deposited. If no coin is detected within 6 seconds after original request for deposit, request will be repeated for retest. If no coin is detected after three additional requests, announcement "TEST HAS ENDED" will be made and test line will disconnect.	Defective chassis	
			Test line recognized a coin other than that deposited. <i>Note:</i> This can occur during the basic sequence if improper coin is deposited or if totalizer generates an improper signal. Test line identifies coin as detected, returns coin, then repeats previous coin request announcement.	Defective totalizer	

TABLE L (Contd)
TROUBLE ANALYSIS – 1C- AND 2C-TYPE SETS
DIAL-TONE-FIRST

STEP	ACTION	VERIFICATION	FAILURE	POSSIBLE CAUSE	REMEDIAL ACTION
19	Listen for coin tones in handset as coins are deposited	Low coin tones heard in handset	Loud coin tones heard in handset	Defective chassis	Replace chassis
20 (Optional)	Deposit additional coins in any sequence if desired; however, a two minute overall time limit is placed on each test call. If this is exceeded, an announcement "TEST HAS ENDED" will be heard, a coin return signal will be generated, and the connection will be broken	Test line will identify coins as deposited	Same as Step 18	Same as Step 18	Same as Step 18
21	Hang up handset	Coins return	Coins do not return	Nonstation trouble	Refer to testdesk
22	Dial the station under test from a nearby telephone or call operator and request operator to call back. Go on hook. Wait for incoming call.	Ringer operates at maximum volume	No ringback or low volume volume	Defective ringer or leads Ringer out of adjustment Open ringer capacitor in network Improper line assignment Nonstation trouble	Replace ringer Adjust Replace chassis Verify and correct Refer to testdesk

TABLE M
TROUBLE ANALYSIS – 1E1 SET
DIAL POSTPAY WHERE ACTS IS NOT AVAILABLE

STEP	ACTION	VERIFICATION	FAILURE	POSSIBLE CAUSE	REMEDIAL ACTION
Preparation For All Tests					
1	Invert handset on switchhook to prevent armored cord from pushing handset off switchhook when cover is set down.				
2	Remove coin cover unit and hang it on a KS-20950, List 2 cover parking tool (Fig. 33). If parking tool is not available or cannot be used at the station, disconnect P1, place coin cover unit on a firm level surface and connect a P11C cord between P1 and J1 of the coin chassis				
3	If set has a 51A hopper, a KS-14995, List 3 tool can be installed between coin chute and hopper to prevent loss of deposited coins. If set has a 50A hopper, test cannot be performed without losing coins.				
Dial Tone Tests					
4.	Go off hook	Dial tone heard	No dial tone	Defective handset.	Replace handset.
				Traffic overload.	Wait and repeat test.
				Switchhook contacts SH1 (NO), or SH2 & SH4 (NO), not making	Clean contacts or replace coin dial unit
				P1 and P2 reversed	Reconnect properly.
				Totalizer in CF mode	Switch to DTF mode
				TB2 not wired correctly.	Wire correctly.
				Defective totalizer.	Replace totalizer.

TABLE M (Contd)
TROUBLE ANALYSIS – 1E1 SET
DIAL POSTPAY WHERE ACTS IS NOT AVAILABLE

STEP	ACTION	VERIFICATION	FAILURE	POSSIBLE CAUSE	REMEDIAL ACTION
Dial Tone Tests					
4 (Contd)				Defective wiring in chassis, or coin dial unit	Replace defective apparatus
5	Dial operator.	Dial tone breaks.	Dial tone does not break.	Nonstation trouble.	Refer to testdesk.
				Defective dial.	Replace defective apparatus
				Defective chassis.	Verify wiring
				TB2 not wired correctly.	Refer to testdesk and correct trouble.
		Operator answers.	Transmission path not established.	Nonstation trouble	Replace handset.
				Defective handset.	
Totalizer Operation					
6	With operator on line, deposit nickel, dime, and quarter.	Operator correctly identifies signal tones.	Operator cannot identify signals properly.	Defective totalizer. Defective chassis. Defective 840708895 hopper delay circuit assembly (51A hopper only) Defective 446F diode. (50A hopper only)	Replace defective apparatus
				Ring and tip reversed.	Correct
				Nonstation trouble	Refer to test desk
7	Listen for coin tones in handset as coins are deposited.	Low tones may be heard	Loud tones are heard	Defective chassis	Replace chassis
8	If KS-14995, L3 tool was installed, disengage chute locking spring; slowly pull top of chute forward while holding KS-14995, L3 tool. Lift chute and tool out of set and retrieve coins.				

TABLE M (Contd)
TROUBLE ANALYSIS – 1E1 SET
DIAL POSTPAY WHERE ACTS IS NOT AVAILABLE

STEP	ACTION	VERIFICATION	FAILURE	POSSIBLE CAUSE	REMEDIAL ACTION
9	Check for noise or cutout in handset cord	Noise should not be heard.	Noise is heard.	Defective handset.	Replace handset.
10	Give operator number of station under test, request operator to call back, go on hook	Ringer operates at maximum volume.	No ring or rings at low volume.	Improper line assignment.	Verify and correct.
				Defective ringer.	Replace ringer or chassis.
				Ringer out of adjustment	Adjust.
				Open capacitor in network.	Replace chassis.
11	Repeat step 3, deposit initial rate, and request operator to identify coin signal	Identification properly made.	Identification cannot be made.	Nonstation trouble.	Refer to testdesk.
12	Repeat step 8. Go on hook				
13	Go off hook, get dial tone, and dial a local charge number (this should be prearranged).	Dial tone received, station number dialed, audible ringing heard, called party answers, deposits coin tone	No dial tone	Traffic overload.	Wait and repeat test.
			Audible ringing not heard		
14	Refer to step 3 and deposit 5 cents less than initial rate	Deposit coin tone remains	Deposit coin tone not heard.	Nonstation trouble	Refer to testdesk.
			Deposit coin tone stops.	Initial rate set incorrectly	Reset rate
			Totalizer reads out.	Wrong code totalizer or defective totalizer.	Replace totalizer.
15	Deposit additional coins up to initial rate.	Deposit coin tone stops. Talk path is established.	Deposit coin tone does not stop.	Defective chassis.	Replace chassis.
			Defective hopper.	Initial rate set for more than the deposit.	Reset rate
			Defective totalizer.	Defective hopper.	Replace defective apparatus.
			Nonstation trouble	Defective totalizer.	Refer to testdesk.

TABLE M (Contd)
 TROUBLE ANALYSIS – 1E1 SET
 DIAL POSTPAY WHERE ACTS IS NOT AVAILABLE

STEP	ACTION	VERIFICATION	FAILURE	POSSIBLE CAUSE	REMEDIAL ACTION
16	If KS-14995, L3 tool was installed, disengage chute locking spring, slowly pull top of chute forward while holding KS-14995, L3 tool. Lift chute and tool out of set and retrieve coins.				
17	Hang up.	Totalizer restores.	Totalizer does not restore.	Defective coin dial unit Defective chassis Nonstation trouble	Replace defective apparatus.
18	Return set to normal operation				Refer to testdesk

TABLE N
TROUBLE ANALYSIS — 1E1 SET
DIAL POSTPAY WHERE ACTS IS AVAILABLE

STEP	ACTION	VERIFICATION	FAILURE	POSSIBLE CAUSE	REMEDIAL ACTION
1	If set has a 51A hopper, a KS-14995, List 3 tool can be inserted between coin chute and hopper to prevent loss of deposited coins. If set has a 50A hopper, test cannot be performed without losing coins.				
2	Go off-hook	Dial tone heard	No dial tone	Defective handset Traffic overload Switchhook contacts SH1 (NO), or SH2 & SH4 (NO), not making	Replace handset Wait and repeat test Clean contacts or replace coin dial unit
				P1 and P2 reversed	Reconnect properly
				Totalizer in CF mode	Switch to DTF mode
				TB2 not wired correctly	Wire correctly
				Defective totalizer	Replace totalizer
				Defective wiring in chassis, or coin dial unit	Replace defective apparatus
				Nonstation trouble	Refer to testdesk
3	Dial ACTS test line	Announcement "COIN TEST" is heard. After one second silence, announcement "PLEASE DEPOSIT NICKEL" is heard.	Announcement not heard. Note: If coin test line is busy, recorder tone will be heard.	Nonstation trouble	Refer to testdesk

TABLE N (Contd)
TROUBLE ANALYSIS – 1E1 SET
DIAL POSTPAY WHERE ACTS IS AVAILABLE

STEP	ACTION	VERIFICATION	FAILURE	POSSIBLE CAUSE	REMEDIAL ACTION
4	Deposit a nickel <i>Note:</i> Dime and quarter are verified in the same manner	Test line identifies coin by announcement "NICKEL" <i>Note:</i> Dime and quarter are verified in the same manner as a nickel	Announcement "TIMING ERROR" is heard <i>Note:</i> If retest is desired, do not hang up. After 1/2 second, "PLEASE DEPOSIT NICKEL" announcement will be repeated No immediate announcement. <i>Note:</i> Coins signals of improper level and/or frequency are not recognized and are treated as if no coin was deposited. If no coin is detected after three additional requests, announcement "TEST HAS ENDED" will be made and test line will disconnect	Defective totalizer Defective totalizer	Replace defective apparatus and repeat test Replace defective apparatus and repeat test in 2.02. (If trouble persists refer to testdesk for loop analysis ie, bridge tap or excessive loading)
5	Listen for coin tones in handset as coins are deposited.	Low coin tones heard in handset	Loud coin tones heard in handset	Defective totalizer	Replace chassis
6	Go on-hook				

TABLE N (Contd)
 TROUBLE ANALYSIS -- 1E1 SET
 DIAL POSTPAY WHERE ACTS IS AVAILABLE

STEP	ACTION	VERIFICATION	FAILURE	POSSIBLE CAUSE	REMEDIAL ACTION
7	Go off-hook, dial operator, and give operator number of station under test, request operator to call back, go on-hook.	Ringer operates at maximum volume	No ring or rings at low volume	Improper line assignment	Verify and correct
				Defective ringer	Replace ringer or chassis
				Ringer out of adjustment	Adjust
8	Go off-hook. Request operator to identify nickel as it is deposited in handset cord	Identification properly made	Identification cannot be made	Open capacitor in network	Replace chassis
				Nonstation trouble	Refer to testdesk
9	Check for noise or cutout in handset cord	Noise should not be heard	Noise is heard	Defective handset	Replace handset
10	Hang up. Retrieve coins				
11	Set with 51A hopper, insert the KS-14995, L3 tool				
12	Go off-hook, get dial tone, and dial a local charge number (this should be prearranged)	Dial tone received, station number dialed audible ringing heard, called party answers, switches to deposit coin tone.	No dial tone	Traffic overload	Wait and repeat test
			Audible ringing not heard	Nonstation trouble	Refer to testdesk
13	Deposit 5 cents less than initial rate	Deposit coin tone remains	Deposit coin tone stops	Initial rate set incorrectly	Reset rate
			Totalizer reads out	Wrong code totalizer or defective totalizer	Replace totalizer
				Defective chassis	Replace chassis

TABLE N (Contd)
TROUBLE ANALYSIS – 1E1 SET
DIAL POSTPAY WHERE ACTS IS AVAILABLE

STEP	ACTION	VERIFICATION	FAILURE	POSSIBLE CAUSE	REMEDIAL ACTION
14	Deposit additional coins up to initial rate	Deposit coin tone stops. Talk path is established	Deposit coin tone does not stop	Initial rate set for more than the deposit Defective hopper Defective totalizer	Reset totalizer Replace defective apparatus
15	Hang up	Totalizer restores	Totalizer does not restore	Nonstation trouble Defective coin dial unit Defective chassis	Refer to testdesk Replace defective apparatus
16	If KS-14995, L3 tool was installed, disengage chute locking spring; <i>slowly pull top of chute forward while holding KS-14995, L3 tool.</i> Lift chute and tool out of set and retrieve coins				
17	Return set to normal operation				

TABLE O
TROUBLE ANALYSIS – 1E3 SET
MANUAL POSTPAY

STEP	ACTION	VERIFICATION	FAILURE	POSSIBLE CAUSE	REMEDIAL ACTION	
Preparation For All Tests						
1	Invert handset on switchhook. <i>Note:</i> Prevents armored cord from pushing handset off switchhook when cover is set down.					
2	Remove coin cover unit and hang it on a KS-20950, L2 cover parking tool (Fig. 33). If parking tool is not available or cannot be used at the station, disconnect P1, place coin cover unit on a firm level surface and connect a P11C cord between P1 and J1 of the coin chassis					
3	Insert KS-14995, L3 tool between coin chute and hopper to prevent loss of deposited coins.					
Dial Tone Tests						
4	Go off hook.	Operator answers	Operator does not answer	Defective handset.	Replace defective apparatus.	
				Defective chassis.		
				Defective switchhook.		
				TB2 not wired correctly.		Verify and correct.
				Nonstation trouble		Refer to testdesk
Totalizer Operation						
5	With operator on line, deposit nickel, dime, and quarter	Operator identifies pro- per coin tone signals	Operator cannot properly identify coin signals	Defective totalizer.	Replace defective apparatus	
				Defective chassis		
				Ring and tip reversed		Correct
				Totalizer mode switch in CF position		Reposition switch to DTF

TABLE O (Contd)
TROUBLE ANALYSIS – 1E3 SET
MANUAL POSTPAY

STEP	ACTION	VERIFICATION	FAILURE	POSSIBLE CAUSE	REMEDIAL ACTION
6	Listen for coin tones in handset as coins are deposited.	Low tones may be heard.	Loud tones are heard.	Defective chassis.	Replace chassis.
7	Disengage chute locking spring, slowly pull top of chute forward while holding KS-14995, L3 tool. Lift chute and tool out of set and retrieve coins.				
8	Check for noise of cutout in handset cord.	Noise should not be heard.	Noise is heard.	Defective handset.	Replace handset.
9	Repeat step 3				
10	Request operator to call back. Go on hook.	Ringer operates at maximum volume.	No ringing or rings at low volume.	Improper line assignment. Defective ringer. Ringer out of adjustment.	Verify and correct. Replace ringer or chassis. Adjust.
11	Call operator, with operator on line deposit a coin and request operator to identify coin signal.	Identification properly made.	Identification cannot be made.	Open capacitor in network. Nonstation trouble.	Replace chassis. Refer to testdesk.
12	Thank operator and hang up.				
13	Disengage chute locking spring, slowly pull top of chute forward while holding KS-14995, L3 tool. Lift chute and tool out of set and retrieve coins.				
14	Return set to normal operation.				

TABLE P

OPERATE VALUES OF COIN RELAYS

MAKING ON RELAY	OPERATING TIME	OPERATE CURRENT	NONOPERATE CURRENT
P-15E687 (Note 1)	Remove from Service		
1A*	450 ± 50 milliseconds	41 milliamps	30 milliamps
1A (Note 2)			

Note 1: On all routine and maintenance visits, replace the existing P-number relay with a 1A-type. P-number relays (650 ms) will not operate proper with No. 5 XBR and ESS offices, and are incompatible with the coin station test line and the KS-21250 test set. P-type relays may be identified by the smaller 5/32-inch diameter restoral spring as compared to the larger 9/32-inch restoral spring on 1A relays as shown in Fig. 7 and 8 or the Public Services Maintenance Check Booklet.

Note 2: Coin relays marked 1A without the asterisk symbol have bifurcated rather than solid contact springs.



Fig. 37—Coin Cover Unit With Handset Inverted

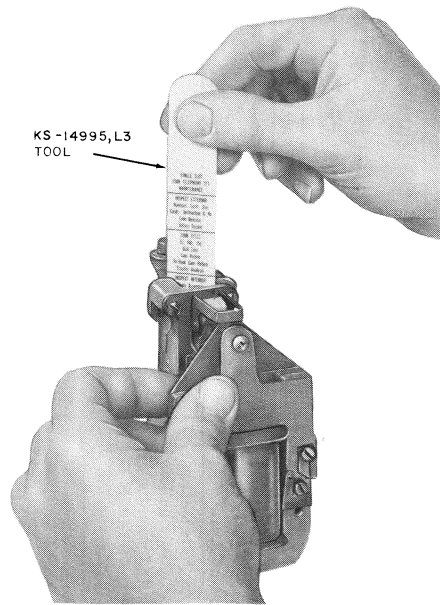

Fig. 38—Trap and Vane Release Test

5. MAINTENANCE

A. Clearing Chute of Foreign Material or Stuck Coin

5.01 When troubles indicate foreign objects or stuck coins in chute.

- (a) Operate coin release lever in attempt to clear coins from chute.
- (b) If trouble does not clear.
 - (1) Remove coin cover unit (1-type) or open door and faceplate assembly (2-type).
 - (2) Remove chute-totalizer.
 - (3) Swing upper plate assembly open (Fig. 39).
 - (4) Where possible, use an orange stick to remove any foreign objects or stuck coins. Do not use screwdriver. Do not loosen chute assembly screw.
 - (5) Clean off any foreign material adhering to chute magnets using a suitable typewriter brush or equivalent.



Exercise extreme care when closing the upper plate assembly. If the quarter divider is not positioned properly, it will become damaged when the upper plate assembly is closed against it.

- (6) Replace 20A coin chute if dime is caught at exist of lower portion of chute (manufactured prior to May, 1978) and chute does not have shims to increase dime exit opening as shown in Fig. 40.

5.02 If trouble cannot be cleared using an orange stick, use a 787A tool (Fig. 41) as follows.

- (a) Remove totalizer from chute.
- (b) Swing upper plate assembly open per Fig. 41.

Note: Several conditions can be encountered with dime jams. Most jams involve only two or three dimes but others may involve as

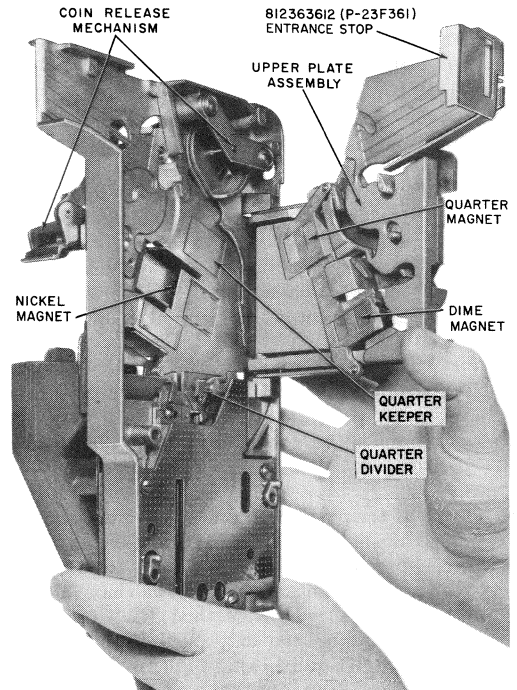

Fig. 39—Chute

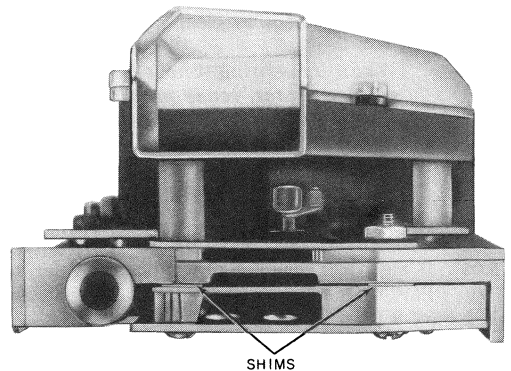

Fig. 40—20A Coin Chute (Manufactured Prior to May, 1978) With Dime Opening Shimmed

many as six dimes blocked at both ends as shown in Fig. 42, with the top two overlapped.

- (c) If two dimes are partially overlapped, the top dime can be hooked on the face and pulled out as shown in Method I (Fig. 43).
- (d) If two dimes are completely overlapped as shown in Fig. 42, proceed as follows.

- (1) Begin unjamming the dimes by inserting the 787A tool as shown in Method II (Fig. 43), hooking onto the dime's edge, and pulling up.

Caution: Do not pull the two overlapped dimes past the lower dime divider leg with the tool hooked on the dime's edge.

- (2) If the overlapped dimes move up together as shown in Method II, any dimes below can probably be shaken out. Access to the overlapped dimes is through the channel from below as shown in Method III. Once the two dimes become only partially overlapped (Method III), utilize Method I to finish extracting them.

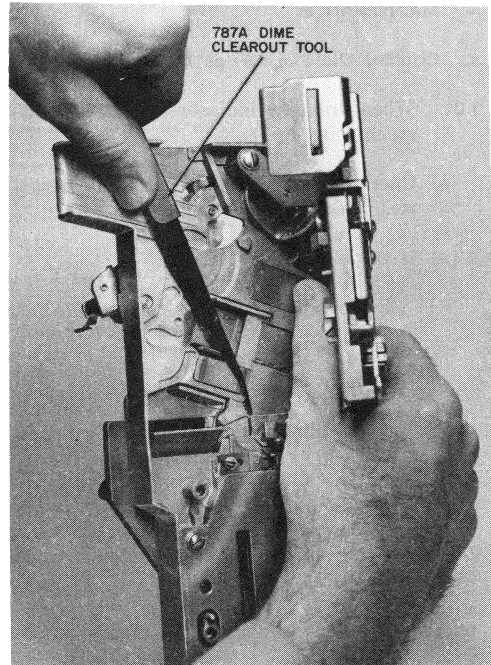

Fig. 41—Using a 787A Dime Clearout Tool in Chute

5.03 Test chute by depositing coins with cover unit assembly both off and on housing (1-type) or with door and faceplate assembly both opened and closed (2-type).

5.04 If trouble cannot be cleared, replace chute.



When returning chute-totalizer to service center, reuse packing material from which the new item was removed.

B. Electrical Troubles

5.05 If electrical troubles are indicated, refer to Part 4 (Operation Tests and Trouble Analysis) and Part 9 (Connections).

5.06 Refer to Part 3 for the removal and replacement of the following components.

- Chute-totalizer
- Chute

- Totalizer
- Coin chassis
- Instruction cards
- Number cards
- Fingerwheel.

5.07 Components other than those listed in paragraph 5.06 can be removed as outlined below.

C. 1A Coin Relay (1A/2A/1C/2C Sets Only)

5.08 To remove 1A coin relay without removing hopper assembly.

- (1) Disconnect (BK) and (Y) leads.

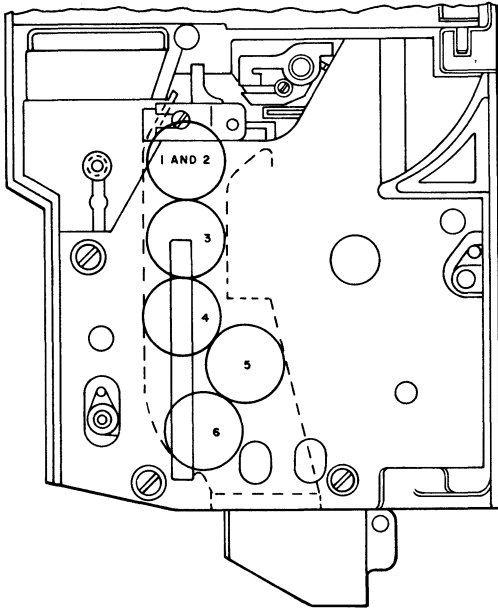

Fig. 42—Lower Portion of Coin Chute With Six Dimes Jammed

- (2) Remove two relay mounting screws on top front of coin relay (Fig. 13).
- (3) Remove two slotted hex head screws on sides of coin relay.
- (4) Check that the hopper trigger (Fig. 44) is in horizontal (up) position and pull off coin relay. **Do not damage hopper trigger.**



When returning defective 1A coin relays to service center, reuse packing material from which the replacing item was removed.

5.09 To install 1A coin relay (Fig. 44).

- (1) Move coin vane to left (collect) position.
- (2) With hopper trigger in nonoperated (horizontal) position, move relay into position until trigger enters T-shaped slot in hopper and trap lever tab just enters opening in selector card.

- (3) Press down slightly on ear of left side of selector card and manually move armature forward to its operated position. Hold armature in this position.
- (4) Move coin relay forward until square stem on vane enters hole in cam and mounting screw holes line up.

Note: Do not attempt to install relay if trigger support bracket is so distorted that mounting holes do not engage hopper bosses.

- (5) Place and tighten evenly two mounting screws on top of coin relay and two slotted hex head mounting screws in each side of relay.

Note: Ensure that top screws are tightened first so that bosses (Fig. 13) will be properly seated.

- (6) Make sure that trigger, armature, trap, and vane operate without binding. Refer to trap and vane release test in Table K.
- (7) Reconnect (Y) lead to terminal G and (BK) lead to terminal 3.

D. Coin Hopper

5.10 To remove coin hopper.

- (1) Remove coin relay from 1A/2A/1C/2C sets.
- (2) In 1E1 sets, disconnect (G) and (S-R) leads from hopper.
- (3) Remove vault door and coin receptacle.
- (4) Remove two 811058098 hex socket head cap screws from inside vault.
- (5) Lift hopper out of set.

5.11 To install coin hopper, use reverse procedure.

- (1) For 1E1 sets, connect (G) and (S-R) leads to hopper in accordance with Fig. 73.

Caution: Observe polarity of diode on 50A hopper. Do not torque the terminal screws excessively to avoid canting the spring pile-up.

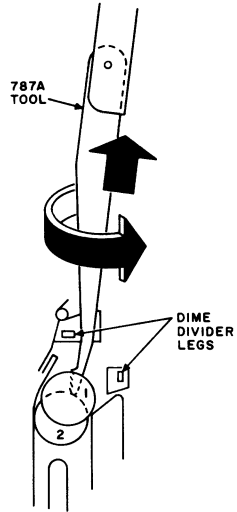
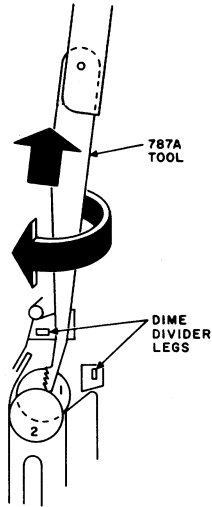

METHOD I

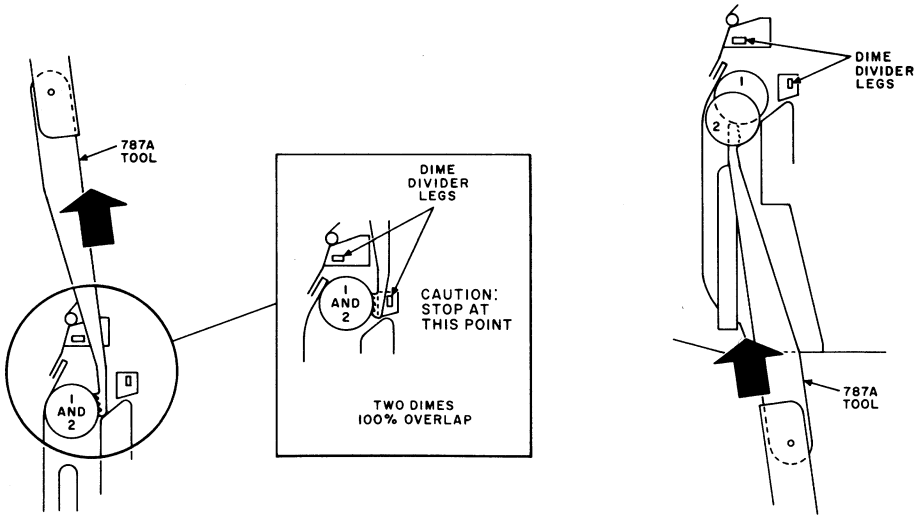

METHOD II

METHOD III

Fig. 43—Method for Removing Jammed Dimes From Chute

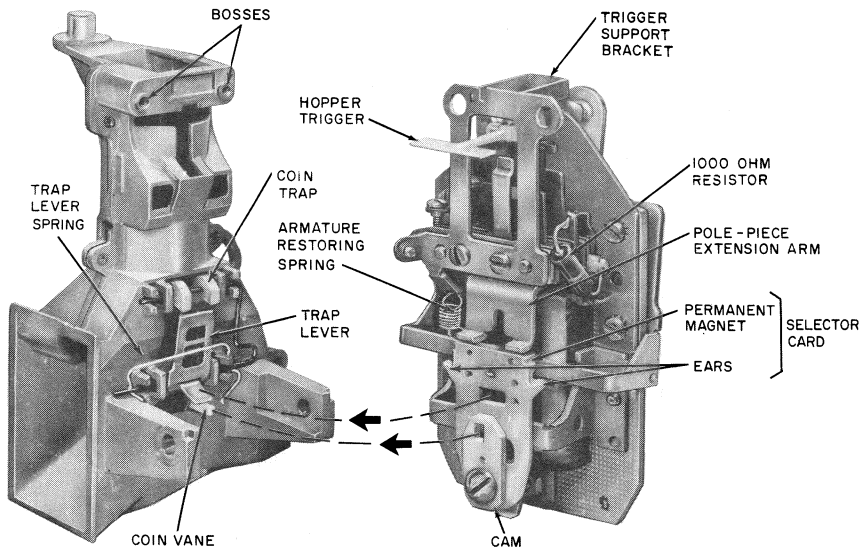

Fig. 44—Coin Hopper and Rear View of Coin Relay

Note: The 840708895 delay circuit assembly on the 51A hopper is replaceable.

E. Coin Trap and Associated Parts (1A/2A/1C/2C Sets Only)

5.12 Check coin trap spring tension as follows.

- (1) Manually operate the coin relay armature to its fully closed position by pushing down on selector card ear (Fig. 44).
- (2) Allow relay to slowly return to its nonoperate position.
- (3) Insert KS-14995, List 3 tool into hopper (Fig. 38). Apply firm downward pressure (approximately 1/2 pound) with tool on coin trap in hopper throat; but **DO NOT FORCE** down enough to bend or break parts.
- (4) If this firm **but not excessive** downward force does not cause the trap lever spring to release the trap, the existing spring is operating adequately. If the armature of the coin relay moves by this action, a new 840157333 wire spring (Fig. 45) should be installed as directed in paragraph 5.13. However if the armature of

the coin relay still moves with the preceding test after spring replacement the trap lever must be replaced.

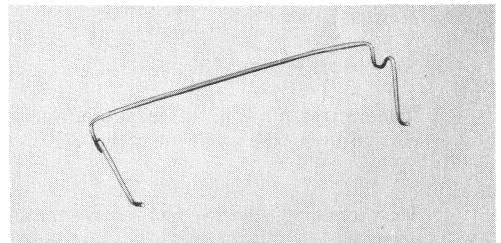

Fig. 45—840157333 Trap Lever Spring

5.13 Install 840157333 trap lever spring as follows (Fig. 46).



The 840157333 trap lever springs may become deformed or twisted when several are intermixed together. This situation can be corrected by grasping each leg of a loose spring with

one's fingers and countertwisting them until both legs are aligned properly as illustrated in Fig. 45.

Note: The phospher bronze spring should be removed before the new wire type spring is installed.

- (1) Remove coin relay, if not previously removed.
- (2) Move trap pin to the right so that left end of pin is flush with hopper guide (Fig. 46, Step 1).
- (3) Holding notched left leg of new spring at an angle away from hopper, slide the right notched leg of the spring under trap pin (Fig. 46, Step 2).
- (4) Swing loose end of spring across face of trap lever and position notch of left leg in alignment with end of trap pin (Fig. 46, Step 3).
- (5) Push trap pin to the left, over and through the left leg notch of the new spring, until the trap pin detents (Fig. 46, Step 4).
- (6) Install coin relay, if applicable.

5.14 To remove trap lever and coin trap.

- (1) Remove coin relay from hopper, if not previously removed.
- (2) Move vane to right.
- (3) Remove trap pin (Fig. 47) by sliding vertical portion over boss on front of hopper.
- (4) Turn coin trap sideways and remove through opening.

5.15 To replace coin trap and trap lever.

- (1) Partially insert trap pin into hole in hopper (Fig. 48) and place trap lever on trap pin.
- (2) Insert coin trap in hopper and engage pin in trap (Fig. 49).



Always use the wire-type trap lever spring (5.13) when installing or replacing a coin trap.

- (3) Push trap pin into position.
- (4) Check operation per Table K.
- (5) Install relay on hopper, if applicable.

F. Return Chute Assembly

Note: Latest return chute assemblies are made of plastic and require special removal techniques.

5.16 To remove return chute assembly.

- (a) Metal return chute.
 - (1) Remove chute-totalizer.
 - (2) Loosen return chute screw (Fig. 13).
 - (3) Lift chute assembly up and off.
- (b) Plastic return chute.
 - (1) Remove chute-totalizer.
 - (2) Loosen return chute screw (Fig. 13).
 - (3) Raise assembly enough to clear round head screw.
 - (4) Holding chute assembly run the screw fully in (this will clear the chute slot and permit removal without chute damage).
 - (5) Lift chute assembly up and off.

5.17 To replace return chute assembly, reverse procedure.

Note: Do not use excessive force when torquing down screw on plastic return chutes. Use only sufficient torque to hold assembly in position.

G. Coin Return Assembly

5.18 To remove coin return assembly.

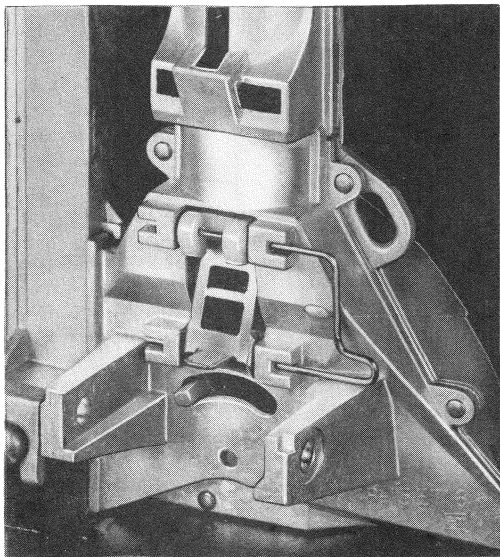

STEP 1

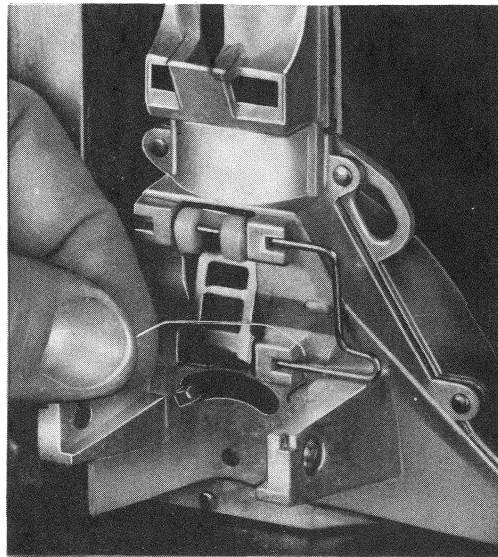

STEP 2

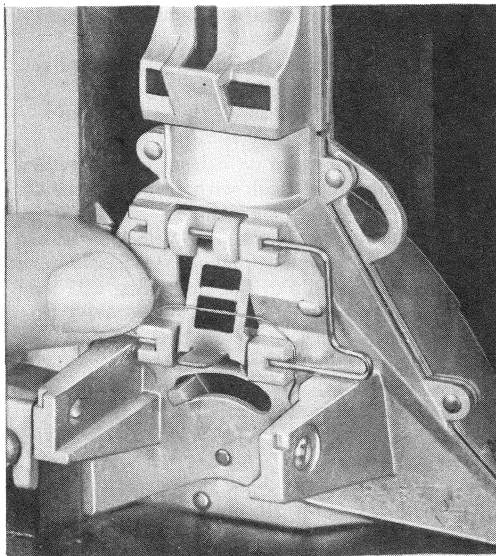

STEP 3

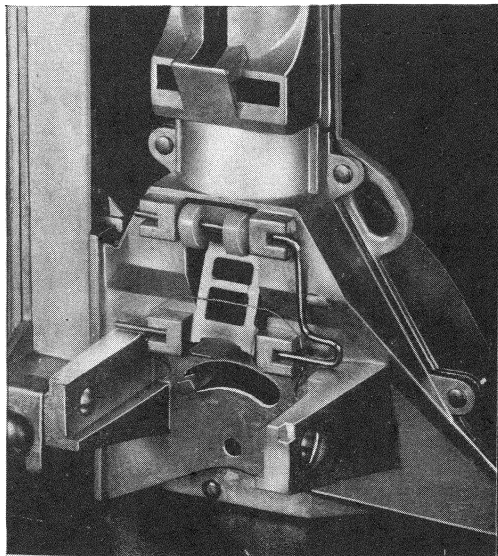

STEP 4

Fig. 46—Installing 840157333 Trap Lever Spring (Typical)

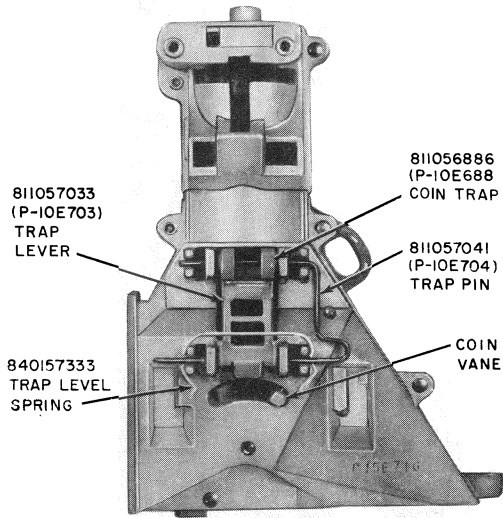

Fig. 47—Coin Trap and Trap Level Assembly

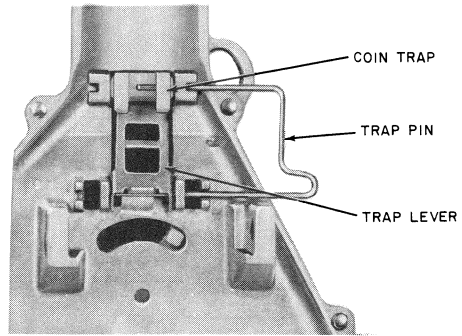

Fig. 49—Placing Coin Trap in Hopper

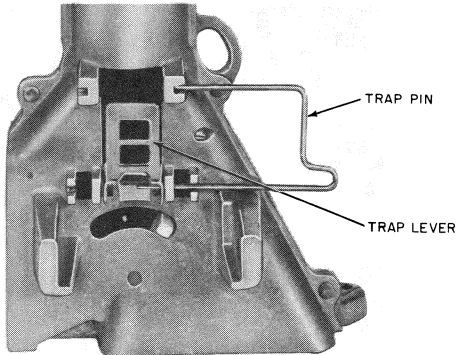

Fig. 48—Placing Trap Lever Pin on Hopper

- (1) Remove chute-totalizer.
- (2) Remove return chute assembly.
- (3) Remove coin return assembly locking screw (Fig. 13).

- (4) Insert finger in coin return and tilt top forward.
- (5) Lift coin return. Pull coin return assembly out and up.

5.19 To install coin return assembly.

- (1) Tilt top of coin return assembly toward set.
- (2) Push coin return assembly into set.
- (3) Push in and down on bottom of coin return assembly until flush with front of housing.
- (4) Install coin return assembly locking screw. Tighten screw only enough to hold return assembly in place. Further tightening will bend screw.
- (5) Replace return chute assembly.
- (6) Replace chute-totalizer.

H. Ringer

5.20 To remove C4A ringer.

- (1) Remove chute-totalizer.
- (2) Remove coin chassis.
- (3) Disconnect four ringer leads; two from TB1 and two from network.

- (4) Remove two ringer mounting screws and lift off ringer.

5.21 To install C4A ringer, reverse procedure making sure that locating pin on bottom of ringer is in grommet on chassis assembly. Make connections per Table Q.

I. Auxiliary Ringer

5.22 Where high ambient noise makes it difficult to hear the C4A ringer in the coin telephone set, a 687A subscriber set can be used to improve the situation. Install the 687A subscriber set as follows.

- (1) Disconnect, insulate, and store the four ringer leads from the ringer in coin telephone set.
- (2) Install an 840362024 capacitor board assembly (Fig. 50).
 - (a) Install capacitor board assembly (Fig. 50) on backplate in 1-type sets.
 - (b) Install capacitor board assembly on rear of 7A clip in panel sets (Fig. 52).
- (3) Interconnect 687A subset and capacitor board assembly, using inside wire, as shown in Fig. 53.

J. Handset

Note: A G13D amplified handset can be used. Refer to Section 501-211-102 for complete information. If G13D handset should require replacement it should only be replaced with another G13D amplified handset.

5.23 The G3AD- and G3AF-type handsets previously used on single slot coin telephone sets are replaced with G3AH- and G3AK-type coded handsets respectively, which have the following features.



Replace handset with black or gray grommets with handsets containing blue grommets.

- (1) They are equipped with an LB-type receiver unit and special field coil adapter in the handset which provides a uniform magnetic field

of use to hard-of-hearing customers having inductive pick up-type hearing aids.

- (2) They are identified by the blue rubber grommet around the armored cord at the transmitter end of the handle.

- (3) G3AHF and G3AKF are optional flame retardant handsets.

- (4) The G3AK and G3AKF handset are equipped with a moisture-proof transmitter barrier and special transmitter cap. (Refer to Section 501-210-102.)

- (5) Transmitter and receiver caps are bonded to the handle.

5.24 To test the field coil adapter in the G3AH, G3AHF, G3AK, or G3AKF handset —

- (1) Place a KS-21468, List 1 tone pick-up coupler (Fig. 54) around the receiver cap of handset.
- (2) Connect a lineman's test set to the two tone coupler terminals.
- (3) Place the TALK-MONITOR switch in the TALK position.
- (4) Dial the 1000 Hz test number from the coin telephone set. Listen in the test set for the 1000 Hz tone.
- (5) If tone is not heard, the field coil adapter is defective and the coin phone handset should be replaced.

5.25 To remove handset.

- (1) Disconnect handset leads from terminal board (TB2) on rear of coin dial unit.
- (2) Remove 801816786 (P-181678) BHM screw, and 811554443 (P-15E444) coverplate (Fig. 1 and 2) which secure handset cord to dial housing.
- (3) Loosen stay-hook screw and remove handset cord.

5.26 To install handset, reverse procedure. Make connections per Table Q.

TABLE Q

COMPONENT CONNECTIONS

COMPONENT	WIRE COLOR	CONNECT TO	
		COIN-FIRST MODE	DIAL-TONE-FIRST OR POSTPAY MODE
Rotary Dial	BL §	TB2-9	TB2-9
	G §	TB2-10	TB2-10
	W	TB2-2	TB2-2
	W	TB2-3	TB2-3
	Y	TB2-9	*
	Y	TB2-9	TB2-13
35T3A TOUCH-TONE Dial	G	TB2-4	TB2-4
	W	TB2-2	TB2-2
	R	TB2-5	TB2-5
	R-G	TB2-6	TB2-6
	BK	TB2-1	TB2-1
	O-BK	TB2-11	TB2-11
	O-R	TB2-12	TB2-12
	BL	TB2-3	TB2-3
	W-BL	TB2-7	TB2-7
	O-W	TB2-10	TB2-9
V	TB2-10	TB2-13	
70A (MD) or 70B TOUCH-TONE Dial	G	TB2-4	TB2-4
	W	TB2-2	TB2-2
	R	TB2-5	TB2-5
	R-G	TB2-6	TB2-6
	BK	TB2-1	TB2-1
	O-BK	TB2-11	TB2-11
	O-R	TB2-10	TB2-10
	W-BL	TB2-7	TB2-7
	O-W	TB2-10	†
	V	TB2-10	TB2-13

TABLE Q (Contd)

COMPONENT CONNECTIONS

COMPONENT	WIRE COLOR		CONNECT TO	
			COIN-FIRST MODE	DIAL-TONE-FIRST OR POSTPAY MODE
Handset (Rotary Set)	G3-Type	G13-Type	TB2-2	TB2-2
	W	G		
	R	R	TB2-3	TB2-3
	BK	BK	TB2-6	TB2-6
	W	Y	TB2-8	TB2-8
	Handset (TOUCH-TONE Set)	W	G	TB2-7
R		R	TB2-3	TB2-3
BK		BK	TB2-5	TB2-5
W		Y	TB2-8	TB2-8
Ringer	BK		TB1-T	TB1-T
	R		TB1-R	TB1-R
	S-R		Term A on Net.	Term A on Net.
	S		Term K on Net.	Term K on Net.
Coin Chassis	G		TB3-1	TB3-2
	G-BK		TB3-2	TB3-3
	R		TB3-3	TB3-1
	S-R		TB3-3	TB3-8
	BL		TB3-4	TB3-6
	S-W		TB3-4	Insulate and Store
	G-W		TB3-5	
	V		TB3-6	
	BK		TB3-7	TB3-4
	W-BR		Insulate and Store	TB3-9
V-O		TB3-6		
R-G		TB3-8		

TABLE Q (Contd)

COMPONENT CONNECTIONS

COMPONENT	WIRE COLOR	CONNECT TO	
		COIN-FIRST MODE	DIAL-TONE-FIRST OR POSTPAY MODE
Switch-hook (Rotary Sets)	R ‡	TB2-12	TB2-12
	G	TB2-13	TB2-9
	S	TB2-9	TB2-9
	BR	TB2-11	TB2-11
	BR	TB2-10	TB2-10
	O	TB2-10	TB2-10
	O	TB2-11	TB2-11
	W	TB2-8	TB2-8
	Y	TB2-3	TB2-3
Switch-hook (TOUCH-TONE Sets)	R ‡	TB2-12	TB2-12
	G	TB2-13	TB2-9
	S	TB2-9	TB2-9
	BR	TB2-11	TB2-11
	BR	TB2-9	TB2-9
	O	TB2-9	TB2-9
	O	TB2-11	TB2-11
	W	TB2-8	TB2-8
	Y	TB2-3	TB2-3

* TB2-9 on dial and housing assemblies 819042748 (P-90D274) and 840152227.

TB2-12 on dial and housing assemblies 841317241 and 841317258.

† TB2-9 on dial and housing assemblies 840155402 and 840155394.

TB2-12 on dial and housing assemblies 840346977 and 840347173.

‡ The (R) switchhook lead appears on the following dial and housing assemblies only:

- 840346977
 - 840347173
 - 840155402
 - 840195394
 - 841317241
 - 841317258
- } TOUCH-TONE Dial
- } Rotary Dial

§ The SWA dial has two (BL) wires instead of a (G) and (BL).

Note: Bold areas indicate differences between CF and DTF modes.

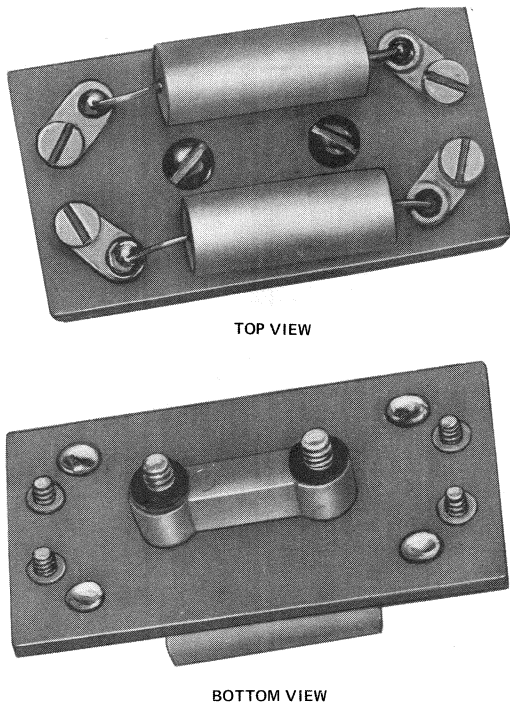

Fig. 50—840362024 Capacitor Board Assembly

K. Coin Dial Unit



The 70A (MD), 70B, and 35T3A TOUCH-TONE dials cannot be physically interchanged without changing the complete dial and housing assembly.

5.27 To remove coin dial unit.

- (1) Remove handset.
- (2) Remove four 840157390 locking mounting screws (Fig. 1 and 2) and remove coin dial unit from cover.

5.28 To install coin dial unit, reverse procedure.

Note: Ensure that the four mounting screws are tight to prevent coin dial unit from becoming loose due to vibration.

5.29 To remove dial.

- (1) Remove mounting screws and pull coin dial unit away from coin cover unit.

Note: It is not necessary to remove handset when removing dial.

- (2) Disconnect dial leads from TB2.
- (3) Loosen two mounting screws on sides of dial through access holes in housing.
- (4) Lift off dial.

Note: Before installing a new rotary dial, remove and discard the dust cover.

5.30 To install dial, reverse procedure making sure that dial is properly seated on four locating pins. Make connections per Table Q.

L. Fingerwheel [8U (MD), 8W (MD), or 8WA Dial]

5.31 To remove fingerwheel refer to paragraph 3.37.

5.32 To install fingerwheel refer to paragraph 3.39.

M. Information Plate and Plate Assemblies

5.33 All current manufactured coin telephone sets are shipped with an information plate (Fig. 1 and 2) indicating mode of service.

5.34 Studded plates for field replacement can be ordered as follows.

- **For Coin-First Service**—840156319 Information Plate equipped with two RM-900077371 thread-forming nuts* and two 840702948 spacers †
- **For Dial-Tone-First Service**—840156327, Assembly, Information Plate equipped with two RM-900077371 thread-forming nuts* and two 840702948 spacers †
- **For Postpay Service**—840156087, Assembly, Information Plate equipped with two RM-900077371 thread-forming nuts.*

TABLE R
D-180893 KIT OF PARTS (POLARITY GUARD) CONNECTIONS
1C2/2C2 COIN TELEPHONE SET, DTF MODE ONLY (NOTE)

LEAD COLOR		REMOVE FROM		CONNECT TO		
TEL SET	POLARITY GUARD*	TB2	NET.	TB2	NET.	POLARITY GUARD
BR		9		11		
O†		11				1
G		4				2
R‡			F		RR	
	G			4		
	O			11		

Note: Can be used with 819042755 (P-90D275), 840157580, 840346977, 840347173 dial and housing assemblies and the 61A coin dial unit.

* The (G) and (O) leads are connected to terminals 3 and 4, respectively, on the polarity guard.

† (O) lead on the 61A coin dial unit connects directly to terminal 1 of polarity guard. On the other four dial and housing assemblies it will be necessary to extend the (O) lead to terminal 1 of the polarity guard using the (O) extension lead and D-161488 connector furnished with the kit.

‡ REMOVE only the (R) lead that connects to pin 7 of component board on coin chassis.

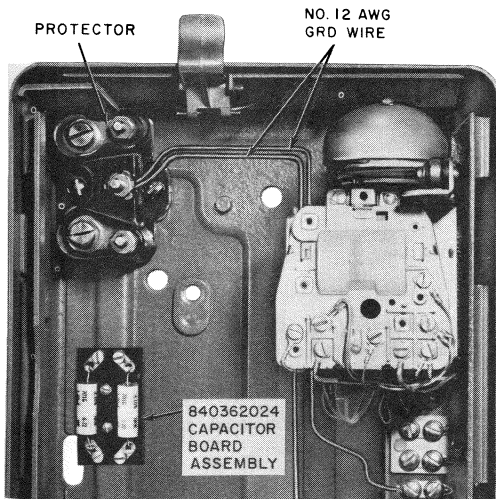

Fig. 51—Housing and Mounting Plate Assembly

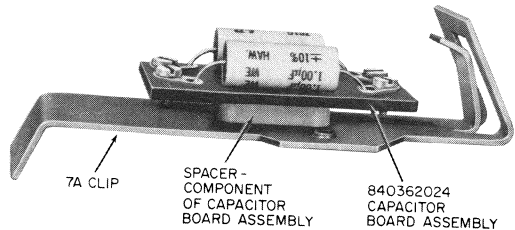

Fig. 52—Capacitor Board Assembly Mounted on 7A Clip

5.35 If sets do not have holes for studded information plates, arrangements can be made to procure studless plates and affix them to the flat surface of the undrilled faceplate.

5.36 To install studless plates on coin telephone set.

*Use a 216B tool (3/8-inch socket wrench) to install or remove nuts from studs.

† Spacers are used on panel phones only.

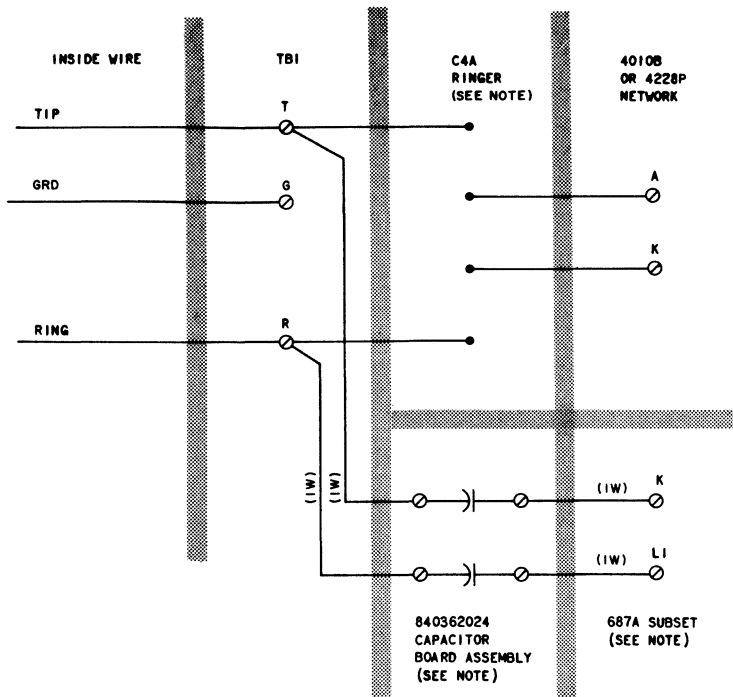
**NOTE:**

DISCONNECT, INSULATE AND STORE THE FOUR RINGER LEADS. MOUNT AN 840362024 CAPACITOR BOARD ASSEMBLY AS DIRECTED IN PART 5. CONNECT CAPACITOR BOARD AND 687A SUBSET AS SHOWN USING INSIDE WIRE. DO NOT PUT THE CAPACITOR OF AN AUXILIARY RINGER IN SERIES WITH THE CAPACITOR BOARD.

Fig. 53—Optional Ringer Connections

- (1) Clean faceplate or panel of dirt and grime using KS-19578, List 1 cleaning fluid.
- (2) Wipe dry with a different, lint-free cloth.
- (3) Apply 3M Company double sided industrial tape No. 9122 (or equivalent) to the back surface of the information plate and trim neatly to size.
- (4) Peel off the back protective tape covering, carefully orient the plate on the faceplate

or front cover (Fig. 1 and 2) and press in place. Apply firm pressure to ensure complete adhesion.

N. Magnetic Coin Stop and Information Plate (D-180848 Kit of Parts)

5.37 A D-180848 Kit of Parts (Fig. 55) is available to install on a 70A- or 71A-type coin cover unit. (It is not designed for a panel set).

5.38 The kit contains a magnetic coin stop assembly with mounting hardware plus a choice of

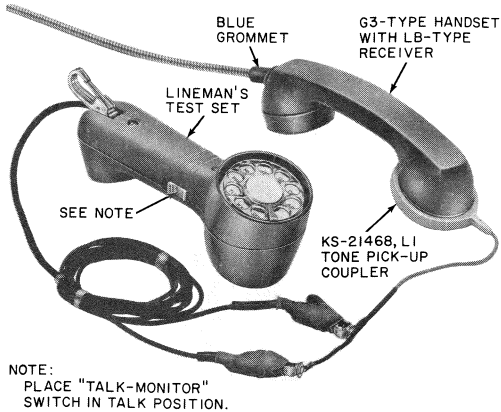

Fig. 54—KS-21468, List 1 Tone Pick-up Coupler

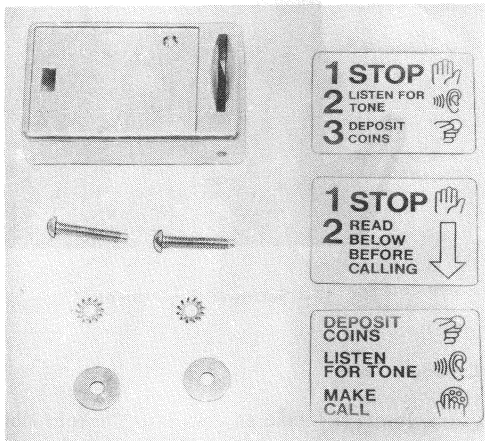

Fig. 55—D-180848 Kit of Parts (Magnetic Coin Stop)

adhesive backed information plates (CF, DTF, or PP service).

5.39 The magnetic coin stop assembly replaces the ceramic information plate that is normally located in this position and will prevent magnetic coins (such as Canadian) from being inserted into the coin chute.

5.40 Replace the CF, DTF, or PP ceramic information plate assembly with a magnetic coin stop assembly as follows.

Note 1: This kit is not adaptable to earlier sets that have an adhesive backed information plate. It is not recommended for field installation where holes for studded information plates do not exist.

Note 2: Do not install this kit on sets where the entrance stop has been positioned off normal as shown in Fig. 60.

- (1) Remove the 70A or 71A-type coin cover unit.
- (2) Remove the existing information plate.
- (3) Thoroughly clean the surface from where the information plate was removed and around the coin slot using an approved cleaner.
- (4) Install the magnetic coin stop assembly over the coin slot and secure it with the two No. 6-32 by 3/4 RHM screws, two No. 6 lockwashers, and two No. 6 flat washers furnished with kit (Fig. 56).
- (5) Clean the front surface of the stop assembly with a dry cloth.
- (6) Observe the information plate removed in (2) and select one from the kit containing the same information.
- (7) Peel off the protective covering from rear and press the information plate in place (Fig. 56). Apply firm pressure to ensure complete adhesion.
- (8) The information plate assemblies (25 plates per package) can be ordered separately as follows.

- 841943467—DTF
- 841943483—CF
- 841943509—PP

5.41 Place the coin cover unit on a flat level surface or hang it on a KS-20950, List 2 parking tool. Perform the following checks and adjustments.

SECTION 506-410-400

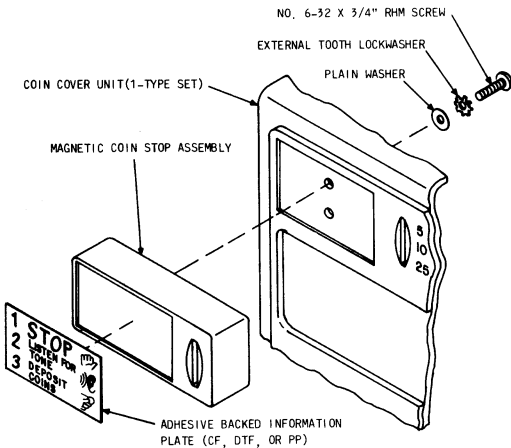

Fig. 56—Installation of the D-180848 Kit of Parts (Magnetic Coin Stop)

CAUTION: If the coin cover unit is tilted forward more than 1-1/2 degrees, an accurate check cannot be made.

U.S. Coins

- (a) A No. 4-40 set screw (Fig. 57) is provided under the coin slot to prevent a U.S. dime from being caught between the magnetic coin stop assembly and faceplate. Make the following adjustments.

Note: See paragraph 5.43 for adjustment using the KS-22551 gauge (optional).

- (1) Turn the set screw clockwise with a No. 4 (.050) Allen wrench until a U.S. quarter will not pass freely through the slot.
 - (2) Turn the set screw counterclockwise until the quarter barely passes through the slot.
 - (3) Turn the set screw an additional half turn counterclockwise to allow clearance for the largest possible quarter.
- (b) Insert a dime, nickel, and quarter into the slot. All coins should pass freely through the magnetic coin stop and coin cover unit.

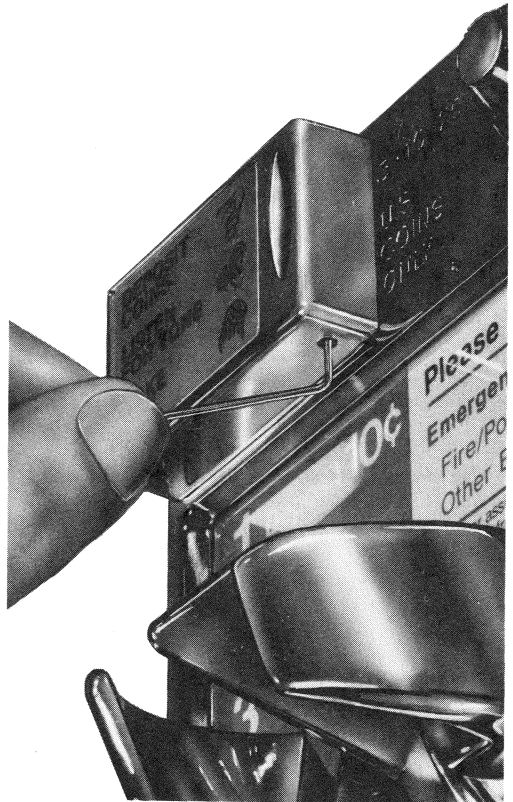

Fig. 57—Setscrew Adjustment

Canadian Coins

- (c) Insert a Canadian coin into the coin slot.

Note: If a Canadian coin is not available insert a suitable screw driver or equivalent into the slot being careful not to push on the shutter when it activates.

- (d) Verify that the shutter on rear of magnetic coin stop fully activates.
- (e) Verify that the shutter returns to its normal position after removal of coin or screwdriver to allow passage of U.S. coins.

5.42 Replace coin cover unit on set.

5.43 A KS-22551 gauge (Fig. 58) is available for adjusting the No. 4-40 setscrew as outlined in paragraph 5.41(a).

- (1) Insert the KS-22551 gauge into the coin slot until it fits flush against the front of the magnetic coin stop assembly (Fig. 59). This may require turning the setscrew counterclockwise.
- (2) Turn the setscrew clockwise until it makes contact with the KS-22551 gauge.
- (3) Remove the KS-22551 gauge.

Note: It may be necessary to turn the setscrew counterclockwise slightly, just enough to free the gauge.

- (4) Proceed with paragraph 5.41(b).

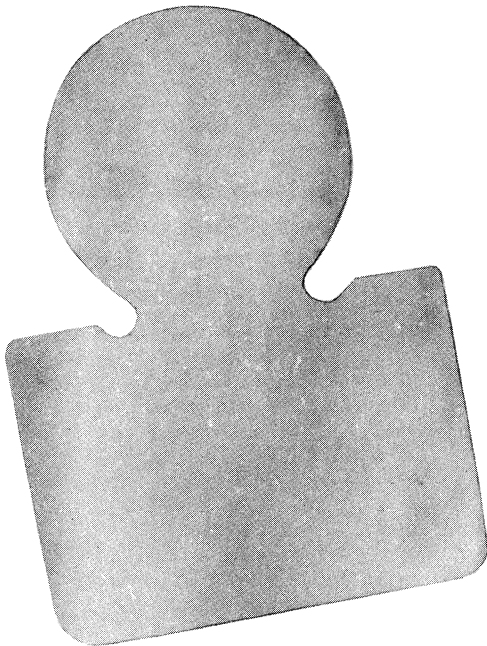

Fig. 58—KS-22551 (Stainless Steel Nonmagnetic) Gauge

O. 812363612 (P-23F361) Entrance Stop

5.44 The entrance stop (Fig. 60) is installed on the chute to minimize coin losses due to chute stuffing. When the coin release lever or knob is operated or a stuffing condition exists the entrance stop moves sideways and closes the coin slot.

5.45 There should be no binding or rubbing of parts when coin releases lever is operated fully and allowed to return to normal without force.

5.46 A prefabricated locking tab arrangement can be bent with a screwdriver (Fig. 60) to hold the upper plate assembly off normal. This will prevent customer coin deposits in newly installed cointelephonesetsawaitinginitialserviceconnections, or those that are out of service which require further maintenance or repair.

Warning: Do not put a set out of service as shown in Fig. 60 if a magnetic coin stop exists, without first removing the coin stop. The magnetic coin stop can be stored in set until service is restored at which time it can be reinstalled. Install an **OUT-OF-SERVICE** sticker.

P. Modification of Cover Unit Chute Guide (Limit Stop)

5.47 If there is a clearance problem between chute and cover unit assembly on the 1-type set, bend the horizontal guide flange, located adjacent to the coin slot inside cover, as shown in Fig. 54.

Q. 840360184 Knob and Shaft Assembly

5.48 The knob and shaft assembly (Fig. 62) can be used to replace the lever-type coin release handle and shaft assembly in areas where vandalism causes damage to internal linkage and other chute actuating components.

5.49 A built-in clutch arrangement ensures that the chute actuating components are neither damaged nor destroyed if the knob is forcibly turned beyond its normal rotational limit.

5.50 To replace the lever-type coin release with the knob-type.



Fig. 59—KS-22551 Gauge Being Used to Adjust No. 4-40 Setscrew

- (1) Remove cover unit assembly (1-type set) or open door and faceplate assembly (2-type set).
- (2) Remove and retain the screw which secures link and lever assembly to coin release lever shaft (Fig. 62). Remove lever and shaft assembly.
- (3) Insert knob and shaft assembly and orient arrow on knob as shown.
- (4) On a panel coin telephone set, the steel spacer must be used.

Note: Do not use spacer on a 1-type set.

- (5) Place link and lever assembly over rear of shaft and secure with the screw retained in (2).

R. 840358725 Handle and Shaft Assembly

5.51 The 840358725 handle and shaft assembly (Fig. 1) can be replaced on the 1-type set as follows.

- (1) Remove coin cover unit.
- (2) Repeat paragraph 5.50(2).
- (3) Insert handle and shaft assembly through faceplate and orient it per Fig. 1.
- (4) Repeat paragraph 5.50(5).

S. Radio Signal Suppression

5.52 For problems involving RFI, refer to Section 500-150-100.

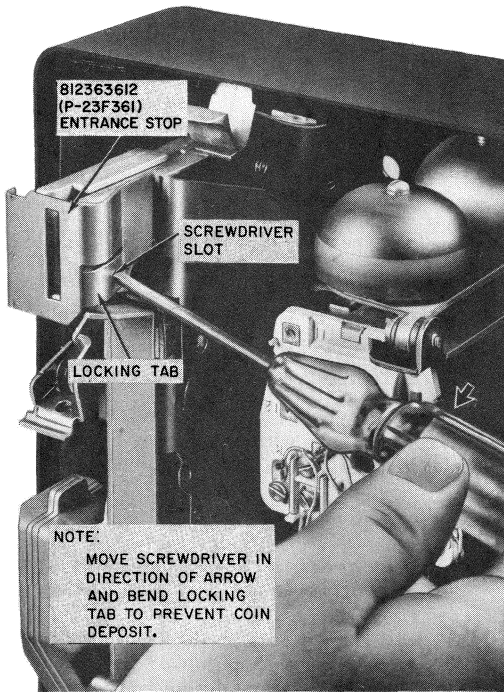

Fig. 60—Operation of Entrance Stop

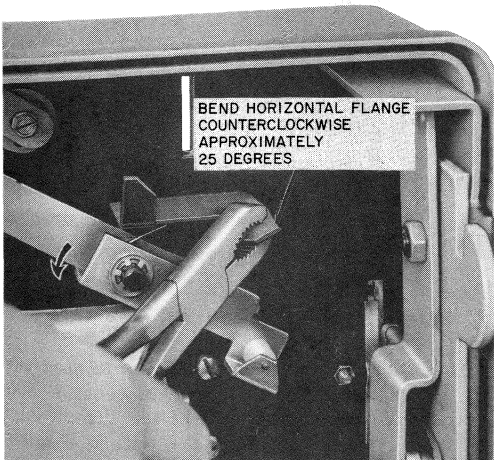
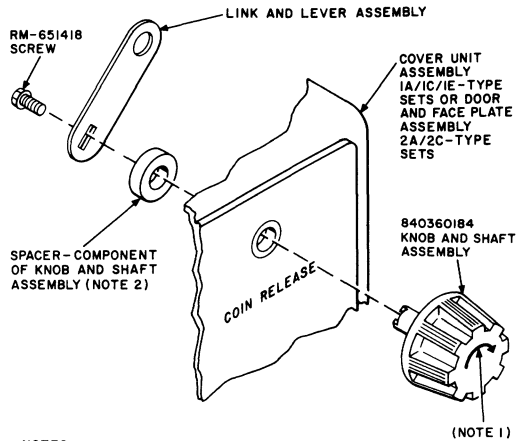

Fig. 61—Bending Chute Guide (Limit Stop)



NOTES:

1. INSTALL KNOB WITH ARROW IN THIS POSITION.
2. USE THIS SPACER ON 2A/2C-TYPE SETS ONLY.

Fig. 62—Installation of 840360184 Knob and Shaft Assembly

T. Polarity Guard (D-180893 Kit of Parts)

5.53 The D-180893 Kit of Parts (polarity guard) may only be used in stations that provide DTF service. The polarity guard provides an enabled TOUCH-TONE dial in the absence of a central office enablement procedure.

5.54 The D-180893 Kit of Parts (polarity guard) is mounted on the bottom left-hand corner of the dial housing (looking at the rear of the housing), directly below TB2. The lower left-hand mounting screw is removed from the housing and inserted into the mounting bracket of the kit. The kit is then fastened into place by inserting the screw into the same hole it was removed from. See Fig. 63.

5.55 For D-180893 Kit of Parts (polarity guard) connections to 1C2/2C2 coin telephone set, DTF mode only, refer to Fig. 63 and to Table R.

5.56 The D-180893 Kit of Parts causes 100 ohms of loss in loop range on nonrange extended loop. The D-180893 Kit of Parts must not be used on range extended loops. It is suggested on range extended loops the D-180707 (conversion to 1D2/2D2

coin telephone set) Kit of Parts be used in place of the polarity guard.

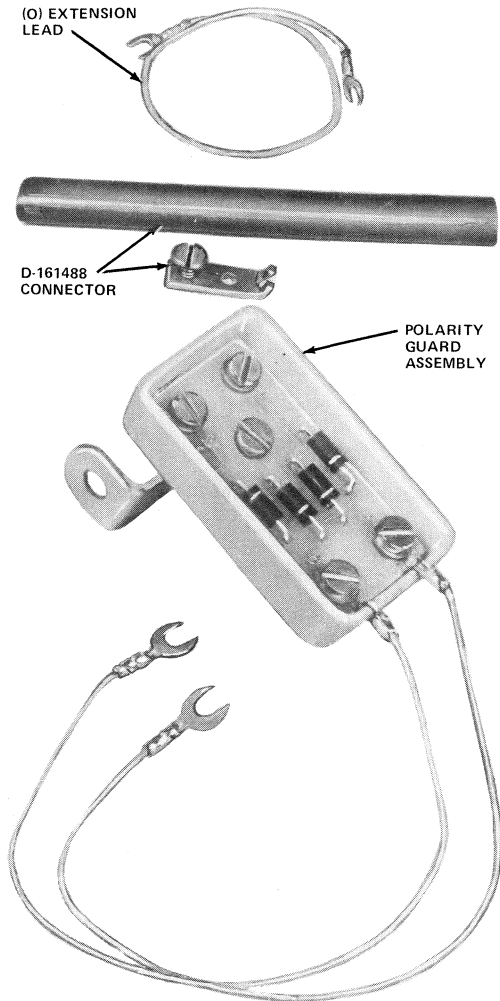

Fig. 63—D-180893 Kit of Parts (Polarity Guard)

6. CONVERSIONS

6.01 *To convert a 1A/2A-type coin telephone set to 1C/2C-type.*

(a) New chute-totalizer, coin chassis, and coin dial unit are required. The following are preferred.

- (1) 20A1A chute-totalizer.
- (2) 31A coin chassis.
- (3) 60-type coin dial unit with rotary dial or 61-type coin dial unit with TOUCH-TONE dial.

Note: On a 1-type set, a complete coin cover unit equipped with appropriate dial can be used.

(b) Replace chute-totalizer, coin chassis, and coin dial unit with components listed in (a). Refer to Parts 3 and 5 for installation procedures.

(c) Verify connections per Table Q.

6.02 *To convert a 1C/2C-type set from CF to DTF mode.*

(a) Use Table Q as a guide and relocate the following where applicable. Bold print in Table Q indicates wiring differences between CF and DTF.

- Two (Y) leads on TB2 (rotary dial only)
- (O-W) and (V) leads on TB2 (TOUCH-TONE dial only)
- All leads on TB3
- (G) switchhook lead on TB2.

(b) Move slide switch on totalizer to DTF position.

(c) Change information plate and instruction cards.

7. MANUAL EXTENSION STATION

7.01 A manual extension station can be used with a 1C/2C-type and 1E3 sets using a 500C desk set equipped with a D-180405 Kit of Parts or a 554-type wall set equipped with a D-180406 Kit of Parts (Section 506-100-108). Do not use a kit-equipped extension set with a 1A/2A-type or 1E1 set.



Not more than one manual extension station should be associated with a coin set if the coin set privacy control feature is needed.

8. CLEANING AND TOUCH-UP

8.01 When necessary, the external surface of the coin telephone set may be cleaned with KS-7860 petroleum spirits or a suitable liquid wax such as Johnson's No. 7700 cleaning and polishing wax emulsion.

Warning: Use safety precautions while using highly flammable KS-7860 petroleum spirits.

8.02 An overspray lacquer, available in 12-ounce aerosol cans can be used for touch up work

on 1-type coin telephone set with vinyl paint finishes.

- KS-21462, List 1 [Black (-03)]
- KS-21462, List 2 [Moss Green (-51)]

8.03 Apply per label instructions on can.



After all maintenance is completed, refer to Part 4 and verify if the coin telephone set is working correctly.

9. CONNECTIONS

9.01 Refer to Fig. 64 through 74 for connecting diagrams.

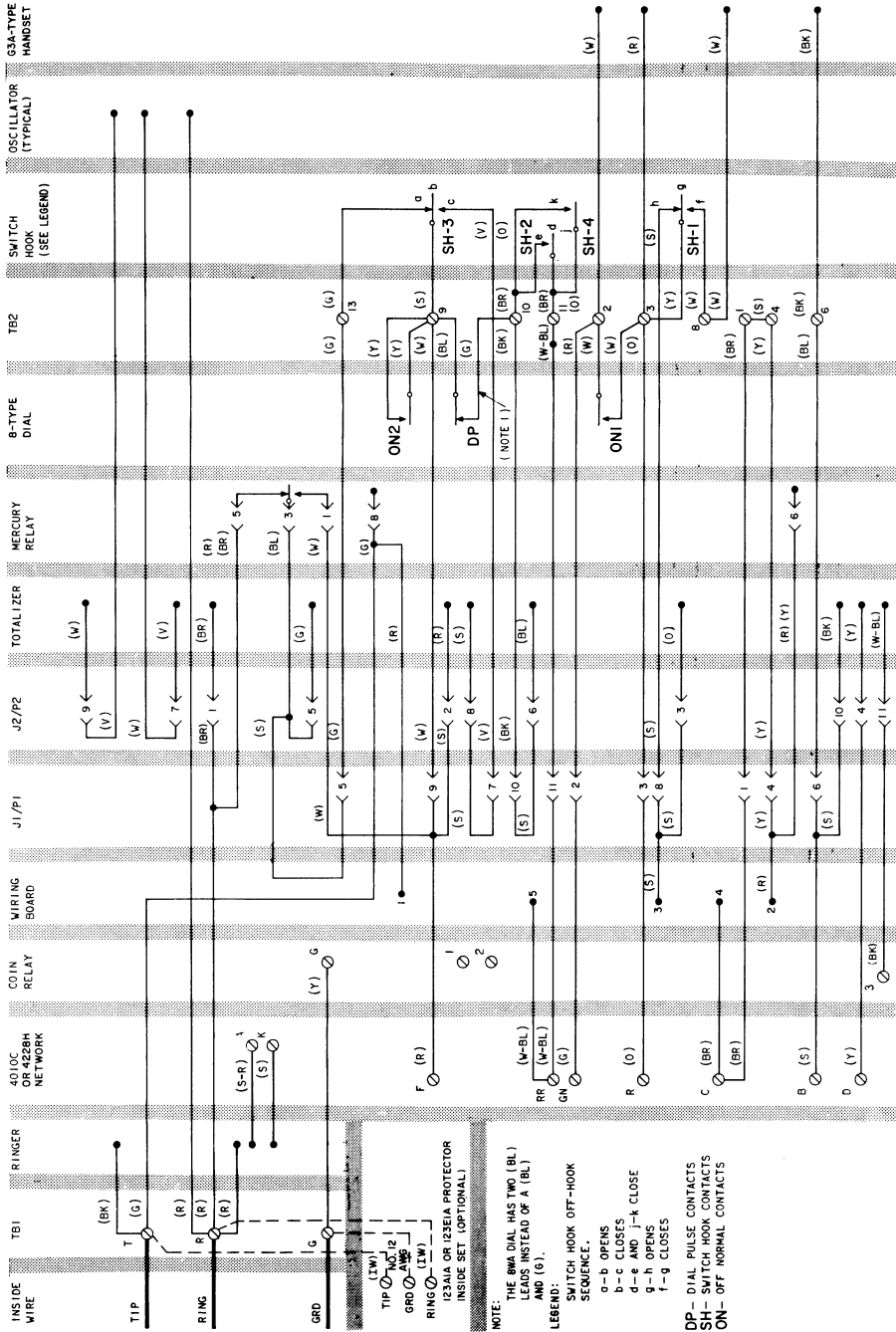

Fig. 64—1A1 of 2A1 Coin Telephone Set—Connections

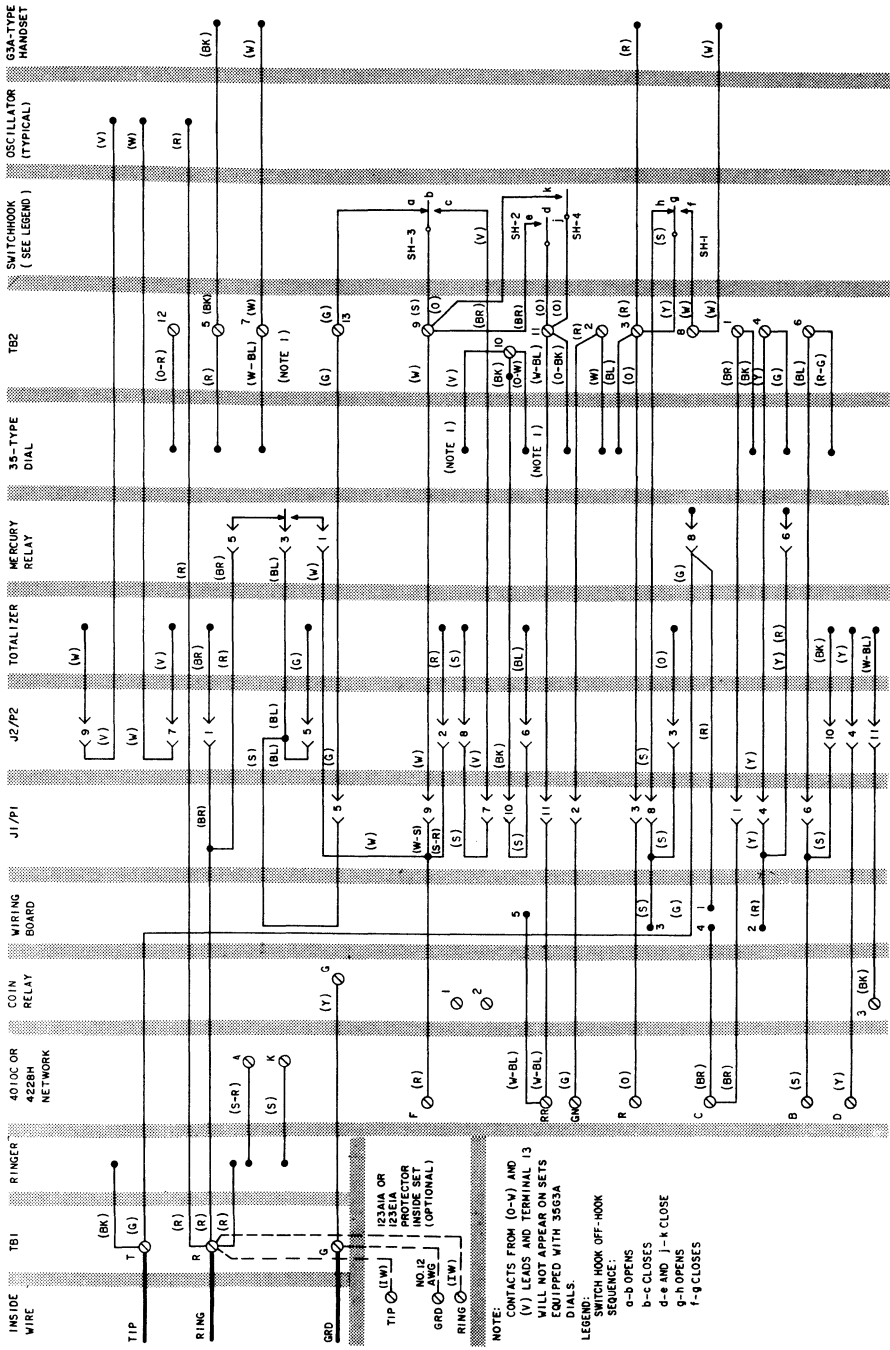

Fig. 65—1A2 or 2A2 Coin Telephone Set W/35T3A Dial—Connections

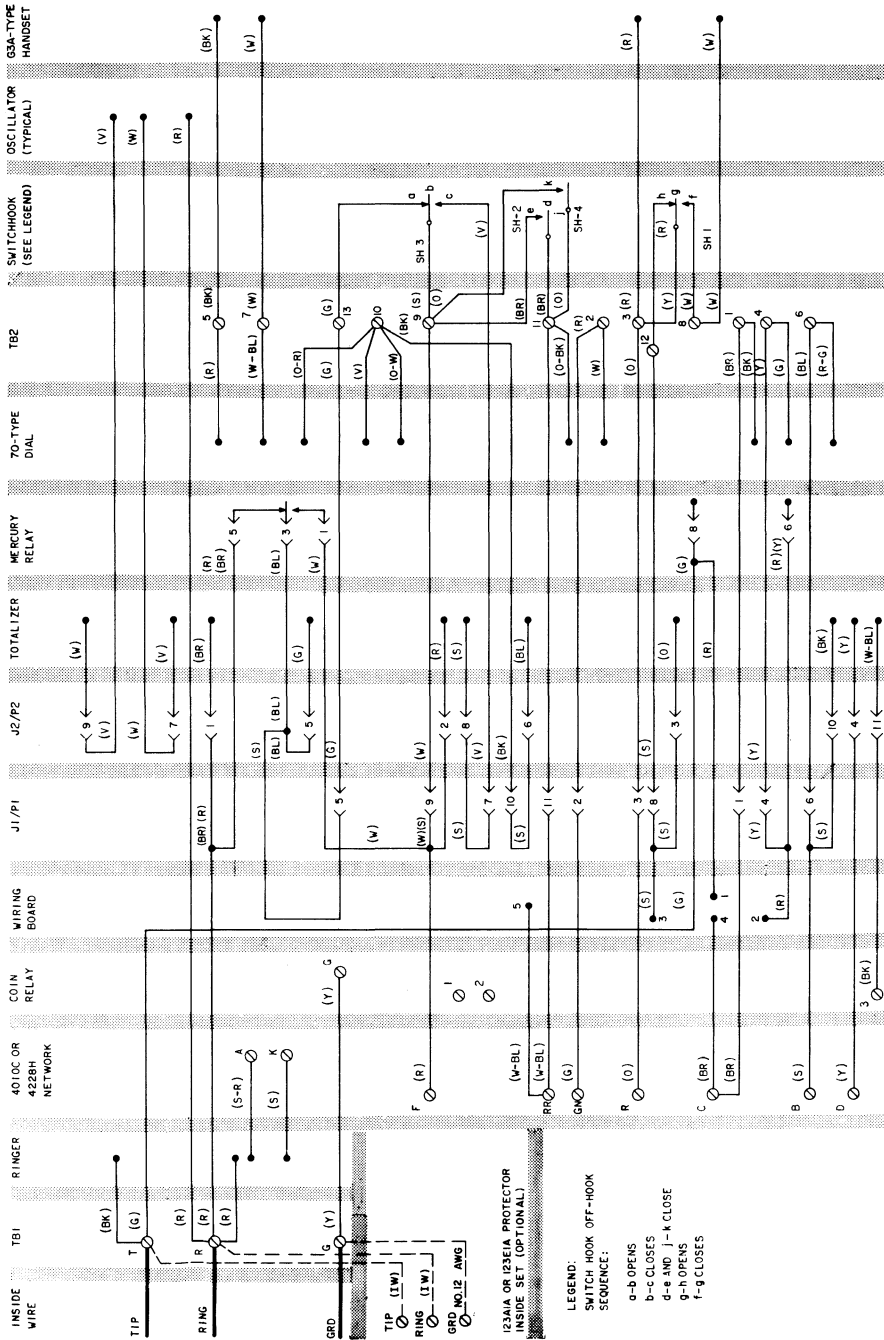

Fig. 66—1A2 or 2A2 Coin Telephone Set W/70-Type Dial—Connections

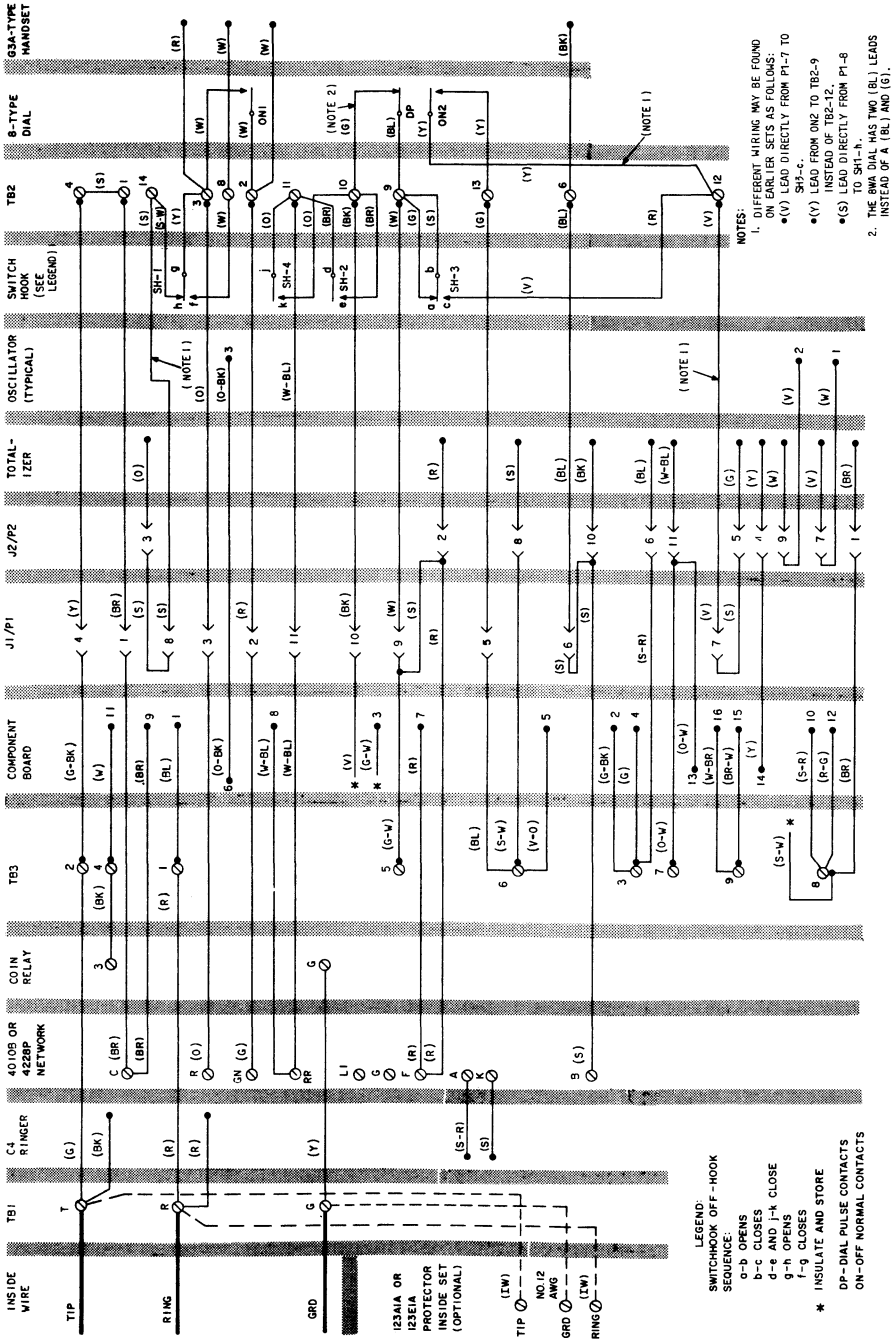

Fig. 68—1C1 or 2C1 Coin Telephone Set—DTF Connections

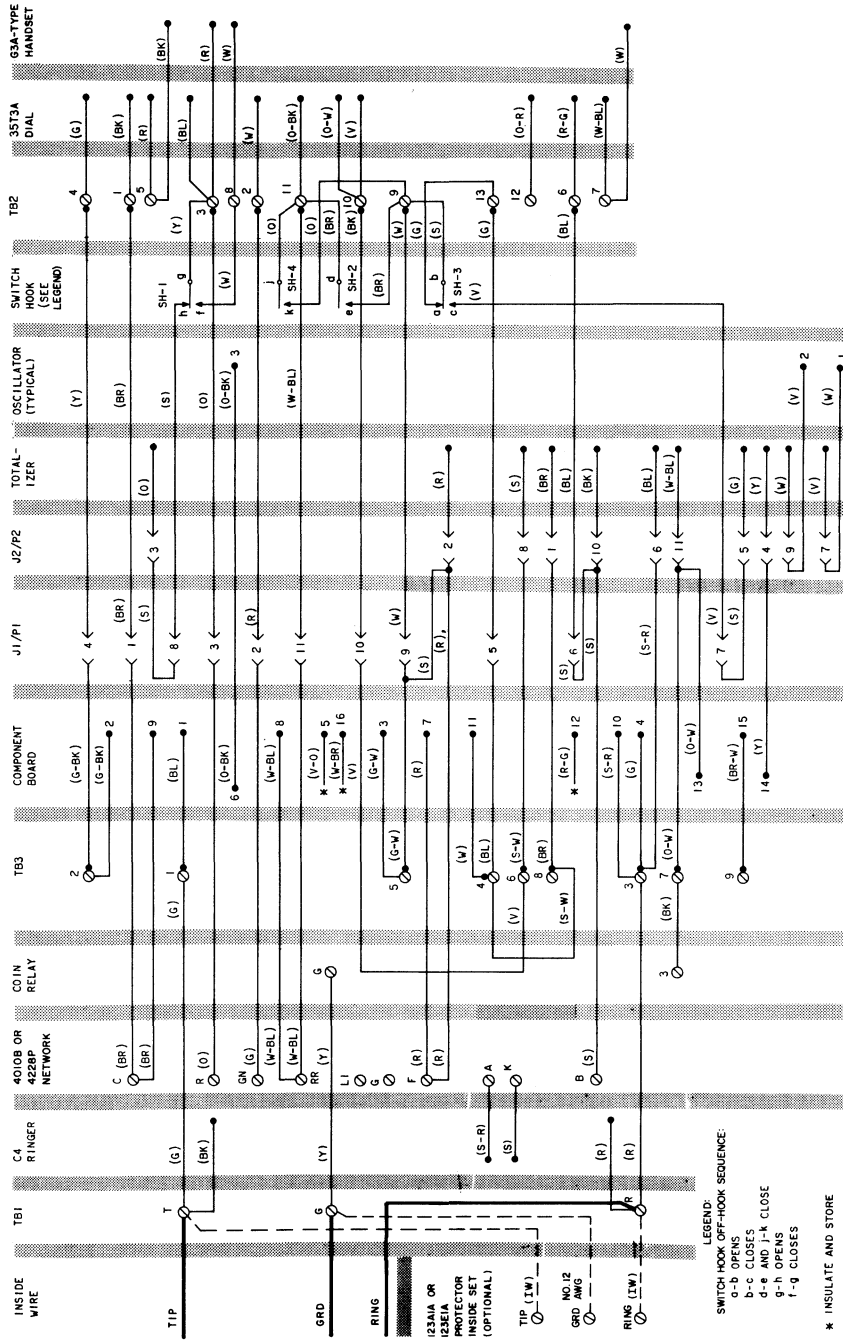
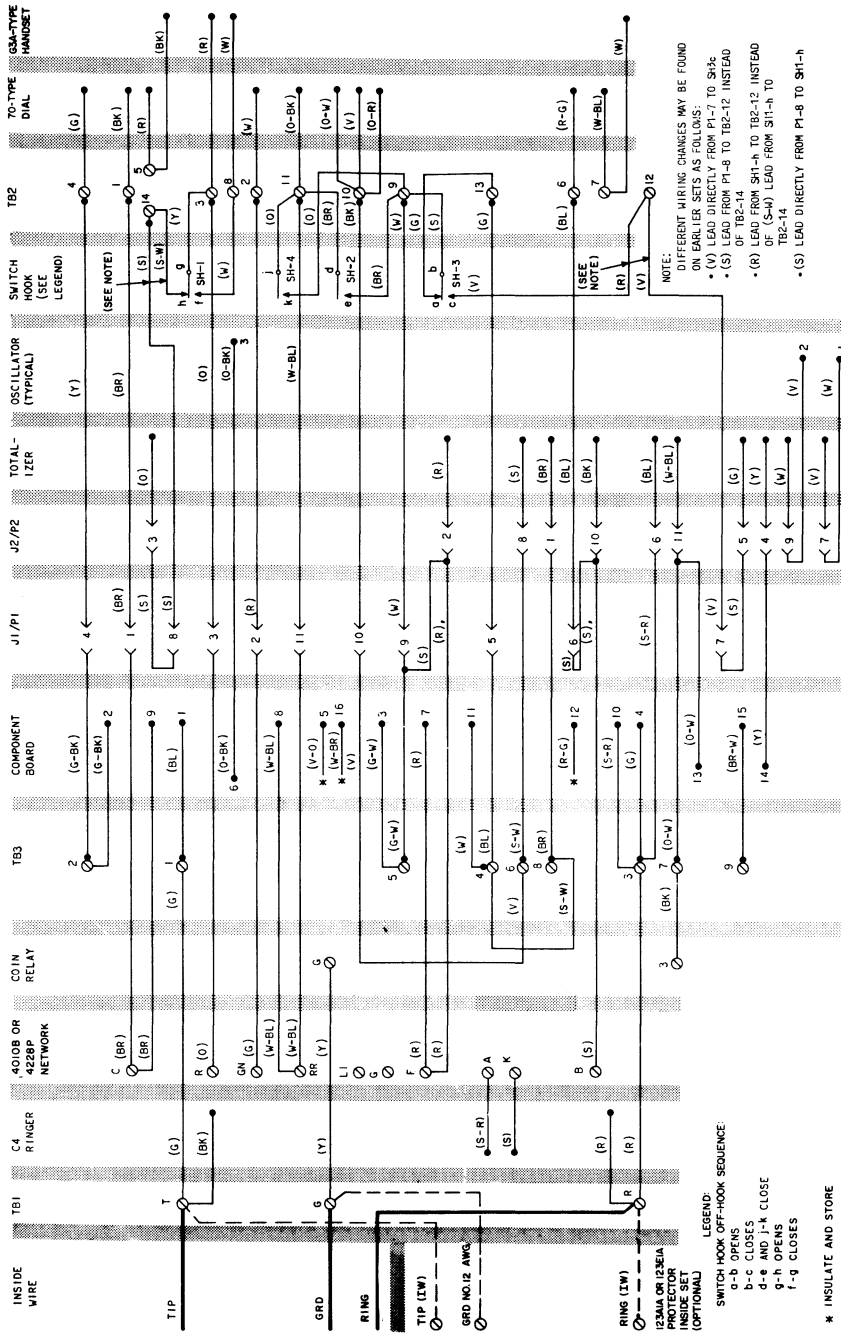

Fig. 69—1C2 or 2C2 Coin Telephone Set W/35T3A Dial—CF Connections



NOTE:
DIFFERENT WIRING CHANGES MAY BE FOUND
ON EARLIER SETS AS FOLLOWS:
• (V) LEAD DIRECTLY FROM P1-7 TO SP4
• (S) LEAD FROM P1-8 TO TB2-12 INSTEAD
OF TB2-10A P1-8 TO TB2-12
• (R) LEAD FROM SH-h TO TB2-12 INSTEAD
OF (S-h) LEAD FROM SH1-h TO
TB2-14
• (S) LEAD DIRECTLY FROM P1-8 TO SH1-h

Fig. 70—1C2 or 2C2 Coin Telephone Set W/70-Type Dial—CF Connections

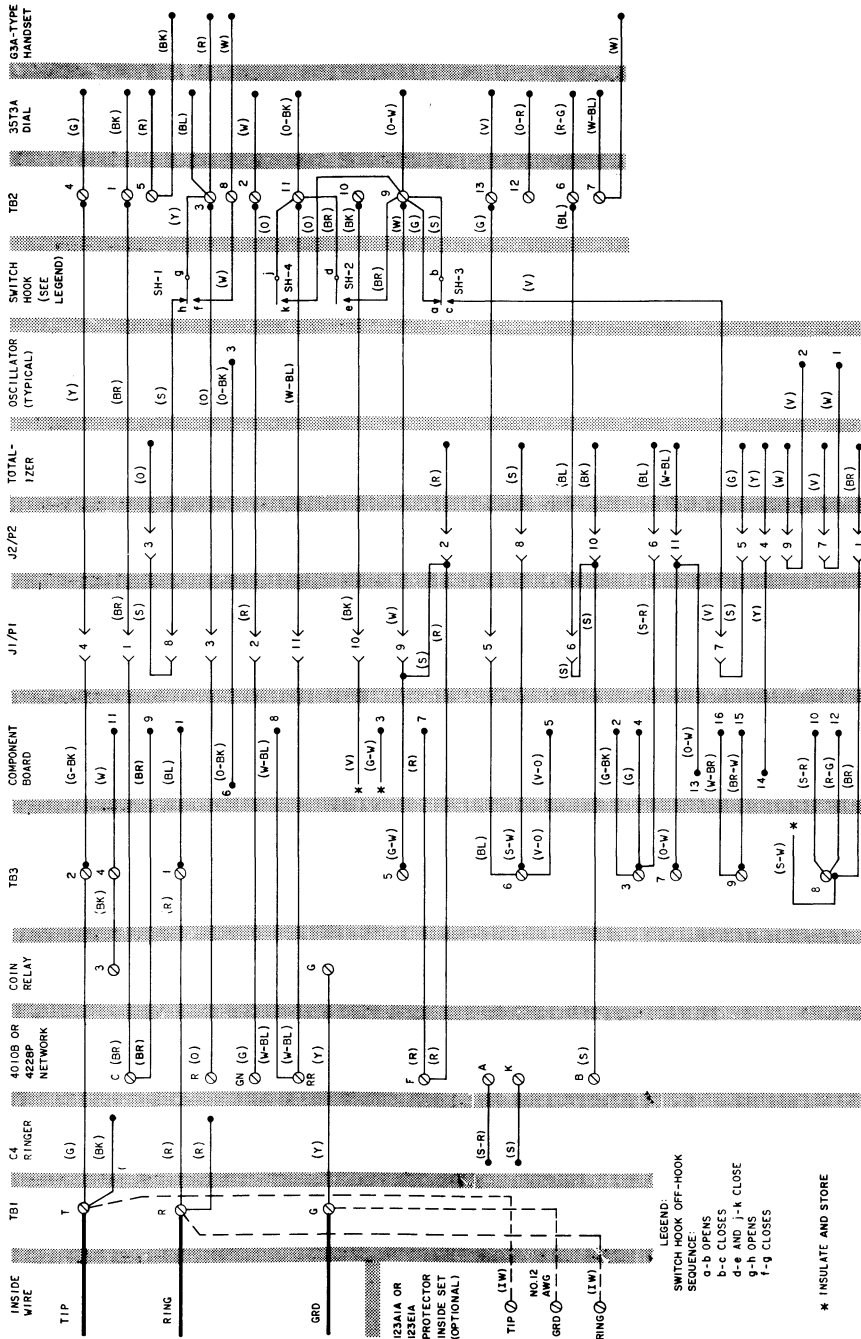

Fig. 71—1C2 or 2C2 Coin Telephone Set W/35T3A Dial—DTF Connections

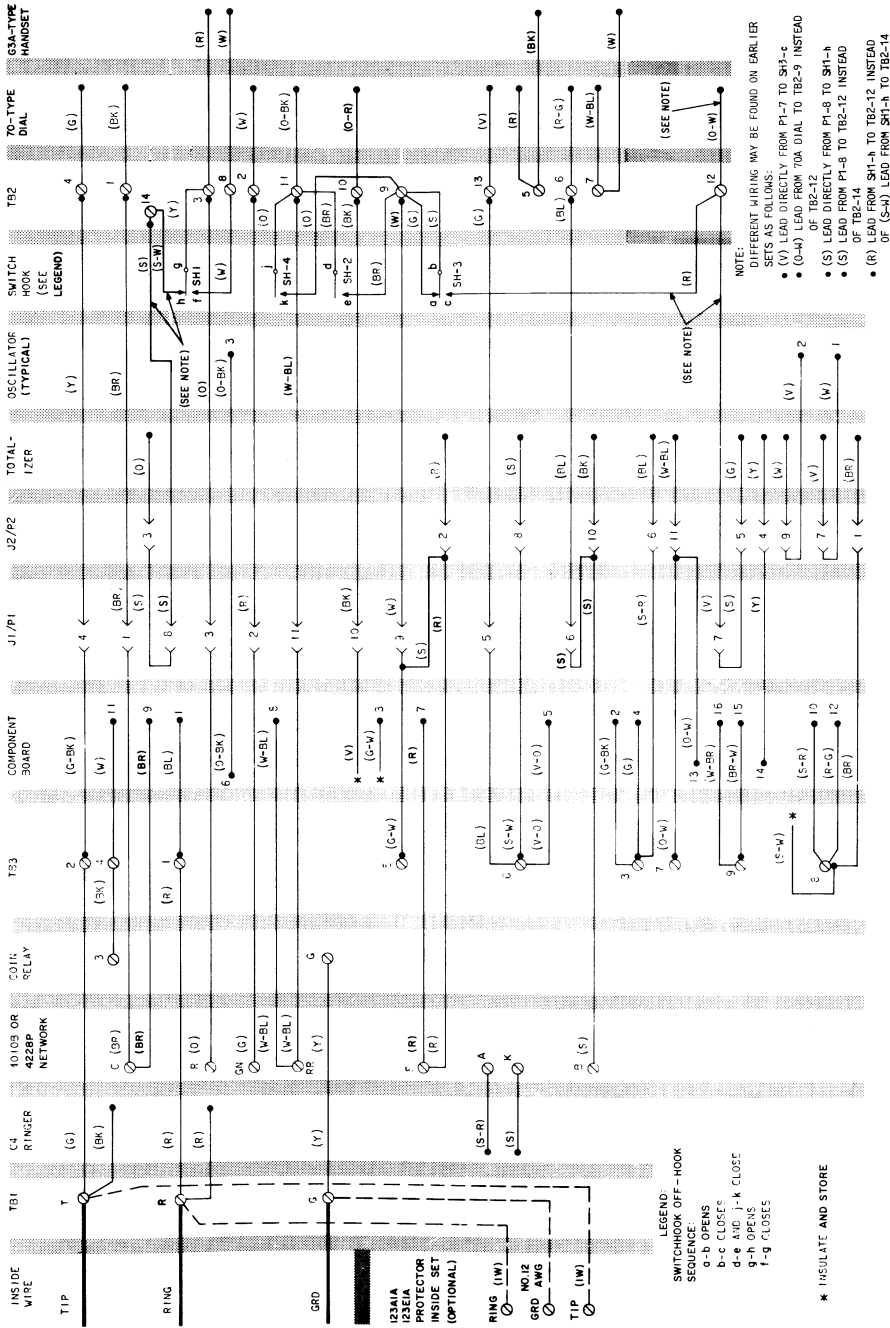
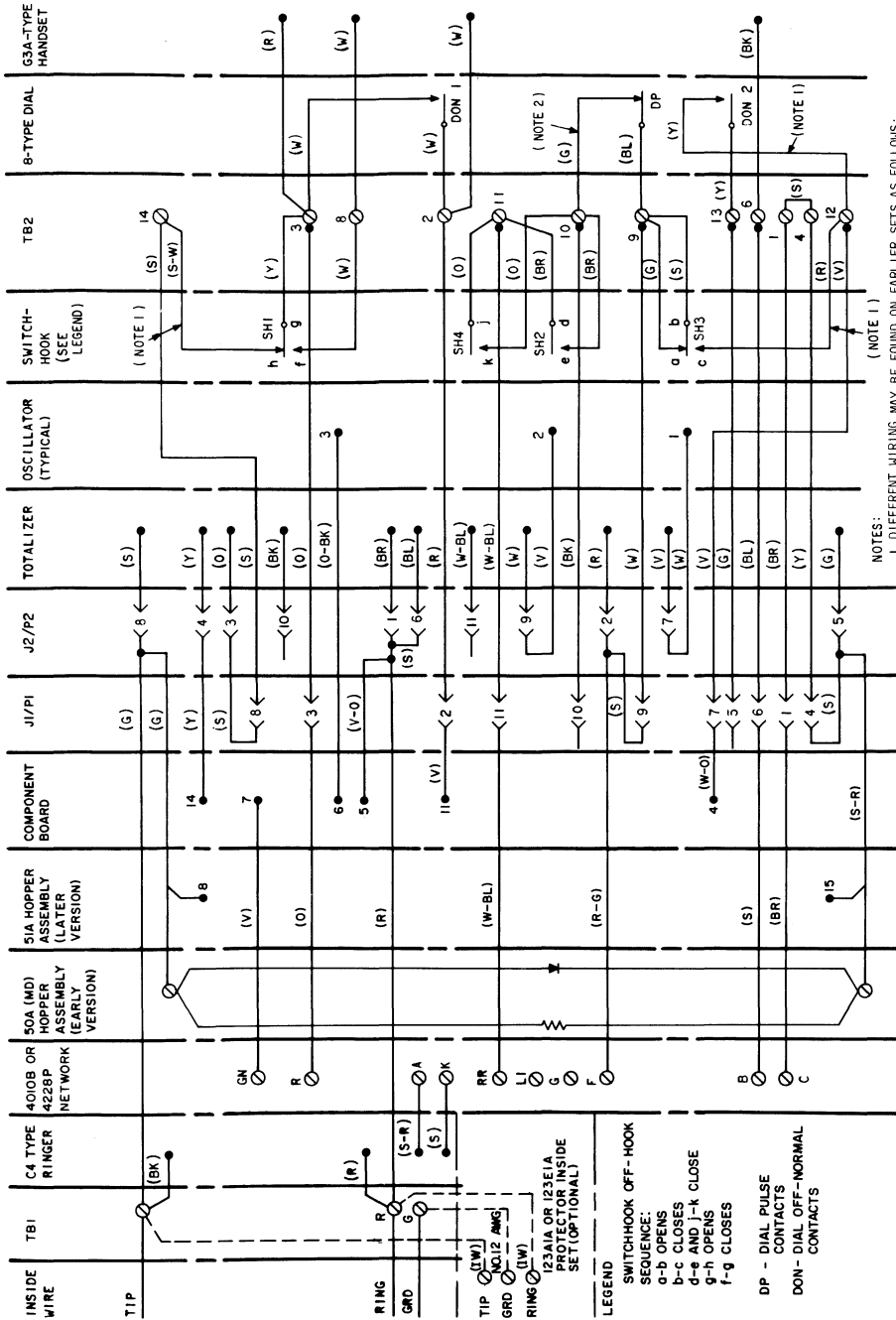

Fig. 72—1C2 or 2C2 Coin Telephone Set W/70-Type Dial—DTF Connections



NOTES:
 1. DIFFERENT WIRING MAY BE FOUND ON EARLIER SETS AS FOLLOWS:
 ● (Y) LEAD DIRECTLY FROM P1-7 TO SH3-c.
 ● (Y) LEAD FROM ON2 TO TB2-9 INSTEAD OF TB2-12.
 ● (S) LEAD DIRECTLY FROM P1-8 TO SH1-h
 2. THE 8WA DIAL HAS TWO (BL) LEADS INSTEAD OF A (BL) AND (G).

LEGEND
 SWITCHHOOK OFF - HOOK SEQUENCE:
 a-b OPENS
 b-c CLOSES
 d-e AND j-k CLOSE
 g-h OPENS
 f-g CLOSES
 DP - DIAL PULSE CONTACTS
 DON - DIAL OFF-NORMAL CONTACTS

Fig. 73—1E1 Coin Telephone Set—Connections

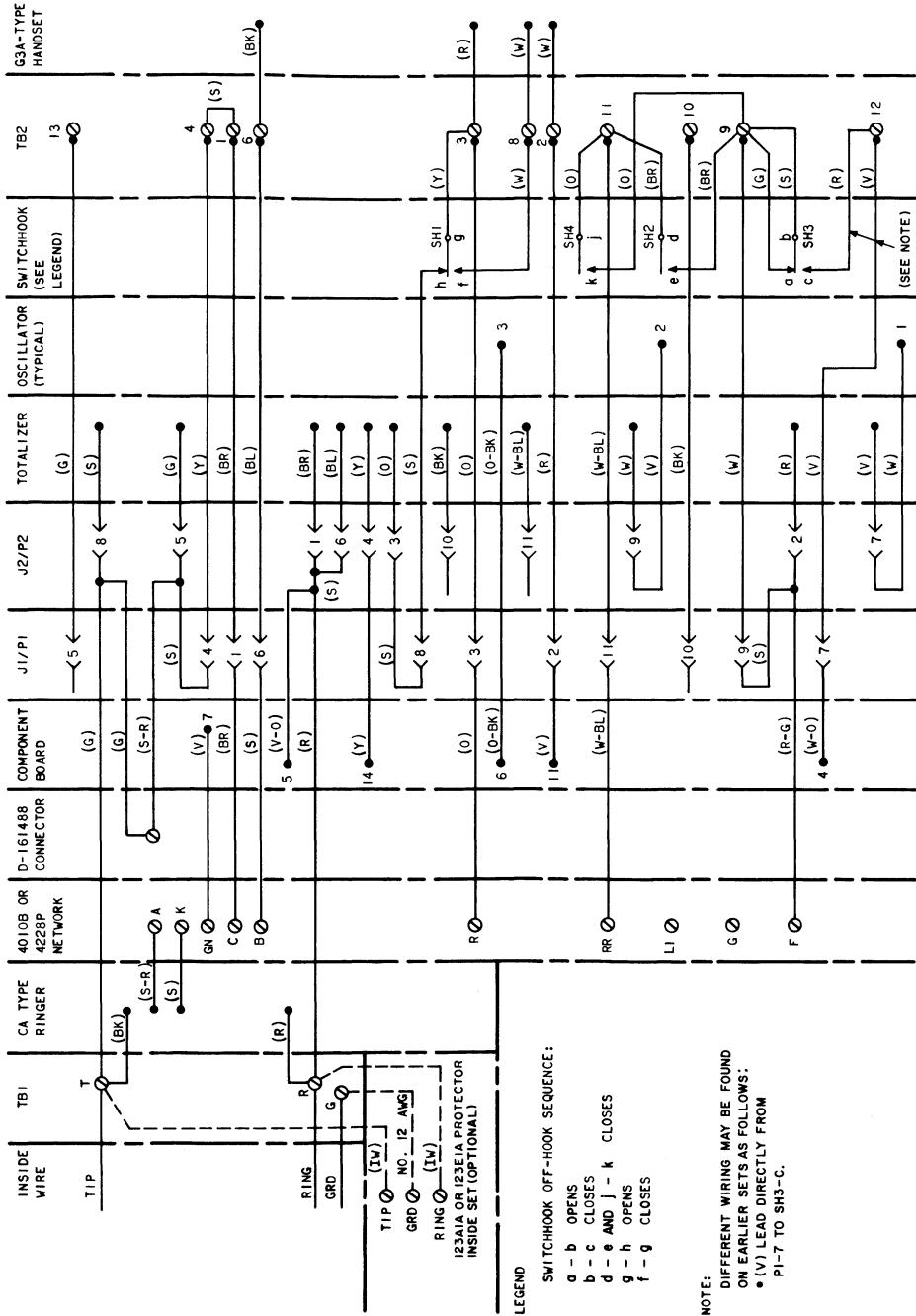

Fig. 74—1E3 Coin Telephone Set—Connections